

**VAX-11/750
H7 104 Power System
Technical Description**

1st Edition, November 1980
2nd Printing (Rev), January 1981

Copyright © 1981 by Digital Equipment Corporation

All Rights Reserved

The material in this manual is for informational purposes and is subject to change without notice.

Digital Equipment Corporation assumes no responsibility for any errors which may appear in this manual.

Printed in U.S.A.

This document was set on DIGITAL's DECset-8000 computerized typesetting system.

The following are trademarks of Digital Equipment Corporation, Maynard, Massachusetts:

DIGITAL
DEC
PDP
DECUS
UNIBUS

DECsystem-10
DECSYSTEM-20
DIBOL
EDUSYSTEM
VAX
VMS

MASSBUS
OMNIBUS
OS/8
RSTS
RSX
IAS

CONTENTS

CHAPTER 1	INTRODUCTION	
1.1	PURPOSE	1-1
1.2	GENERAL DESCRIPTION OF H7104 POWER SYSTEM.....	1-1
1.2.1	Configuration.....	1-1
1.2.2	Function.....	1-4
1.2.3	Controls and Indicators.....	1-5
1.3	RELATED DOCUMENTATION	1-5
1.3.1	Field Maintenance Print Set.....	1-5
1.3.2	VAX-11/750 Technical Descriptions	1-5
CHAPTER 2	POWER SYSTEM SPECIFICATIONS AND OPERATING INSTRUCTIONS	
2.1	H7104A, B POWER SYSTEMS	2-1
2.1.1	875A, B Power Controller Assemblies.....	2-2
2.1.2	H7104C + 2.5 V Power Supply Assembly	2-4
2.1.3	H7104D + 5 V Power Supply Assembly	2-5
2.2	OPERATING INSTRUCTIONS	2-7
2.2.1	Turn-On Procedure.....	2-7
2.2.2	Turn-Off Procedure	2-7
CHAPTER 3	MECHANICAL CONFIGURATION AND CABLING	
3.1	MECHANICAL CONFIGURATION	3-1
3.1.1	H7104C + 2.5 V Power Supply Assembly	3-1
3.1.2	H7104D + 5 V Power Supply Assembly	3-1
3.1.3	875A, B Power Controller Assemblies.....	3-1
3.2	CABLING	3-2
3.2.1	AC Power Distribution	3-2
3.2.2	DC Power Distribution	3-2
3.2.2.1	DC Power Distribution to CPU Backplane	3-2
3.2.2.2	DC Power Distribution to UNIBUS Option Backplane and TU58 Control Board	3-3
3.2.3	Airflow Sense.....	3-3
3.2.4	Temperature Sense	3-4
3.2.5	Distribution of Power Supply Bias Voltages.....	3-4
3.2.6	Control Signal Distribution	3-4
3.2.7	Status Display Signals	3-5
3.2.8	Battery Backup Unit Cabling	3-5
3.2.9	Grounding.....	3-6
CHAPTER 4	FUNCTIONAL THEORY OF OPERATION	
4.1	H7104 POWER SYSTEM.....	4-1
4.2	AC POWER DISTRIBUTION AND CONTROL.....	4-4
4.3	AC INPUT, RAW DC, AND H7104 BIAS VOLTAGE POWER SUPPLY	4-8
4.3.1	AC Input and Raw DC Sections.....	4-8
4.3.2	H7104 Bias Voltage Power Supply.....	4-11

4.4	+ 5 V POWER SUPPLY	4-12
4.4.1	Regulation of +5 V, 10 to 135 A Output	4-12
4.4.2	+5 V Overvoltage Protection	4-16
4.4.3	+5 V Overcurrent Protection	4-16
4.4.4	Low Level AC Input Protection	4-16
4.4.5	+5 V Monitor Circuits	4-16
4.5	± 15 V REGULATOR	4-17
4.5.1	Regulation of +15 V, 0.2 to 2 A Output	4-17
4.5.2	Regulation of -15 V, 0.35 to 3.5 A Output	4-19
4.5.3	± 15 V Regulators Overcurrent Protection	4-20
4.5.4	± 15 V Regulators Overvoltage Protection	4-20
4.5.5	± 15 V Regulators Monitor Circuits	4-20
4.6	AC INPUT, RAW DC, AND +2.5 V POWER SUPPLY	4-20
4.6.1	AC Input and Raw DC Sections	4-20
4.6.2	+2.5 V Power Supply	4-23
4.6.2.1	Regulation of +2.5 V, 8.5 to 85 A Output	4-23
4.6.2.2	+2.5 V Overvoltage Protection	4-24
4.6.2.3	+2.5 V Overcurrent Protection	4-25
4.6.2.4	Low Level AC Input Protection	4-25
4.6.2.5	+2.5 V Monitor Circuits	4-25
4.7	± 5 VB REGULATORS	4-25
4.7.1	Regulation of +5 VB, 2 to 20 A Output	4-28
4.7.2	+5 VB Regulator Overcurrent Protection	4-29
4.7.3	+5 VB Regulator Overvoltage Protection	4-29
4.7.4	Regulation of -5 VB, 0 to 1.2 A Output	4-29
4.7.5	-5 VB Regulator Overcurrent Protection	4-30
4.7.6	-5 VB Regulator Overvoltage Protection	4-30
4.7.7	± 5 VB Regulators Monitor Circuits	4-30
4.8	+ 12 VB REGULATOR	4-30
4.8.1	Regulation of +12 VB, 1 to 10 A Output	4-30
4.8.2	+12 VB Regulator Overcurrent Protection	4-32
4.8.3	+12 VB Regulator Overvoltage Protection	4-33
4.8.4	+12 VB Regulator Monitor Circuit	4-33
4.9	FAULT DETECT AND STATUS DISPLAY	4-33
4.10	TIME-OF-YEAR BATTERY	4-36
4.11	BATTERY BACKUP UNIT, H7112	4-38
4.11.1	Battery Charger Functional Description	4-38
4.11.2	Battery Power Source Functional Description	4-40
4.12	DC POWER DISTRIBUTION	4-40

CHAPTER 5 FAULT ISOLATION PROCEDURES AND REMOVAL AND REPLACEMENT INSTRUCTIONS

5.1	FAULT ISOLATION	5-1
5.2	BATTERY BACKUP OPERATIONAL VERIFICATION	5-10
5.3	REMOVAL AND REPLACEMENT INSTRUCTIONS	5-15
5.3.1	+ 5 V Power Supply Assembly Removal Procedure	5-15
5.3.2	+ 5 V Power Supply Assembly Installation Procedure	5-16
5.3.3	+ 2.5 V Power Supply Assembly Removal Procedure	5-17
5.3.4	+ 2.5 V Power Supply Assembly Installation Procedure	5-18
5.3.5	Power Controller Removal Procedure	5-19
5.3.6	Power Controller Installation Procedure	5-20

FIGURES

Figure No.	Title	Page
1-1	Outline Drawings: 875 Power Controller, H7104C +2.5 V Power Supply Assembly, and H7104D +5 V Power Supply Assembly.....	1-2
4-1	H7104 Power System Block Diagram.....	4-2
4-2	AC Power Distribution and Control Functional Block Diagram	4-5
4-3	AC Input, Raw DC, and H7104 Bias Voltage Power Supply Functional Block Diagram.....	4-9
4-4	+5 V Power Supply Functional Block Diagram	4-13
4-5	±15 V Regulators Functional Block Diagram	4-18
4-6	AC Input, Raw DC, and +2.5 V Power Supply Functional Block Diagram	4-21
4-7	±5 VB Regulators Functional Block Diagram.....	4-26
4-8	+12 VB Regulator Functional Block Diagram	4-31
4-9	Fault Detect and Status Display Functional Block Diagram	4-34
4-10	Battery Backup Unit Functional Block Diagram.....	4-39
5-1	H7104 Power System Fault Isolation Guide.....	5-2

TABLES

Table No.	Title	Page
1-1	Controls and Indicators.....	1-5
1-2	Related Drawings.....	1-8
1-3	Related Manuals	1-9
4-1	Operational Functions and Related Assemblies	4-3
4-2	Fault Condition Versus Status Display	4-37
4-3	DC Power Distribution and Approximate Power Requirements for VAX-11/750 Modules	4-41
5-1	Fault Isolation Procedures	5-3

CHAPTER 1 INTRODUCTION

1.1 PURPOSE

This document presents the technical description for the H7104 power system as configured for use with the VAX-11/750. The technical data provided describes the assemblies comprising the H7104 power system, discusses the relationship between assemblies, and provides fault isolation procedures to aid in repair of the power system. This document is intended for use by DIGITAL field engineers and/or customer personnel trained by Educational Services of DIGITAL.

1.2 GENERAL DESCRIPTION OF H7104 POWER SYSTEM

The H7104 power system as configured for use with the VAX-11/750 comprises an 875 power controller, an H7104C +2.5 V power supply assembly, an H7104D +5 V power supply assembly, an ac harness, a control cable assembly, and a remote +2.5 V sense cable assembly. Outline drawings of the 875 power controller, H7104C +2.5 V power supply assembly, and H7104D +5 V power supply assembly are shown in Figure 1-1.

1.2.1 Configuration

There are two configurations of the H7104 power system: H7104A for use with 120 Vac, single-phase, 50/60 Hz facility power input and H7104B for use with 240 Vac, single-phase, 50/60 Hz facility power input. The H7104A operates over a range of 90 to 128 V at 47 to 63 Hz. The H7104B operates over a range of 180 to 256 V at 47 to 63 Hz.

The H7104A power system comprises the following:

1. 875A power controller (7015929-00)
2. H7104C +2.5 V power supply assembly (7016157-01)
3. H7104D +5 V power supply assembly (7016156-01)
4. AC harness (7016153-00)
5. Control cable assembly (7016513-00)
6. Remote +2.5 V sense cable assembly (7016516-00)

The H7104B power system comprises the following:

1. 875B power controller (7015929-01)
2. H7104C +2.5 V power supply assembly (7016157-01)
3. H7104D +5 V power supply assembly (7016156-01)
4. AC harness (7016153-00)
5. Control cable assembly (7016513-00)
6. Remote +2.5 V sense cable assembly (7016516-00)

Other assemblies related to the H7104 power system as configured for use with the VAX-11/750 include a blower motor assembly, an airflow sensor, time-of-year battery, and control panel assembly. A battery backup unit (H7112) may be incorporated into the power system as an option.

875 POWER CONTROLLER

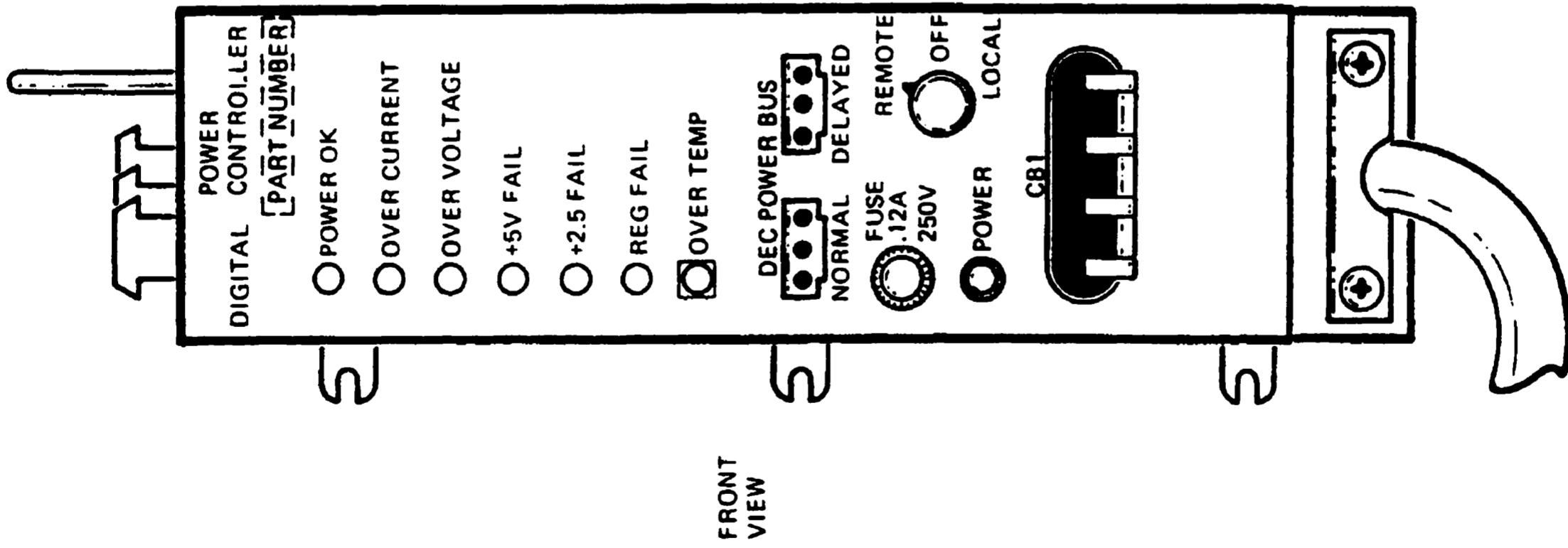

H7104C
+2.5V POWER SUPPLY
ASSEMBLY

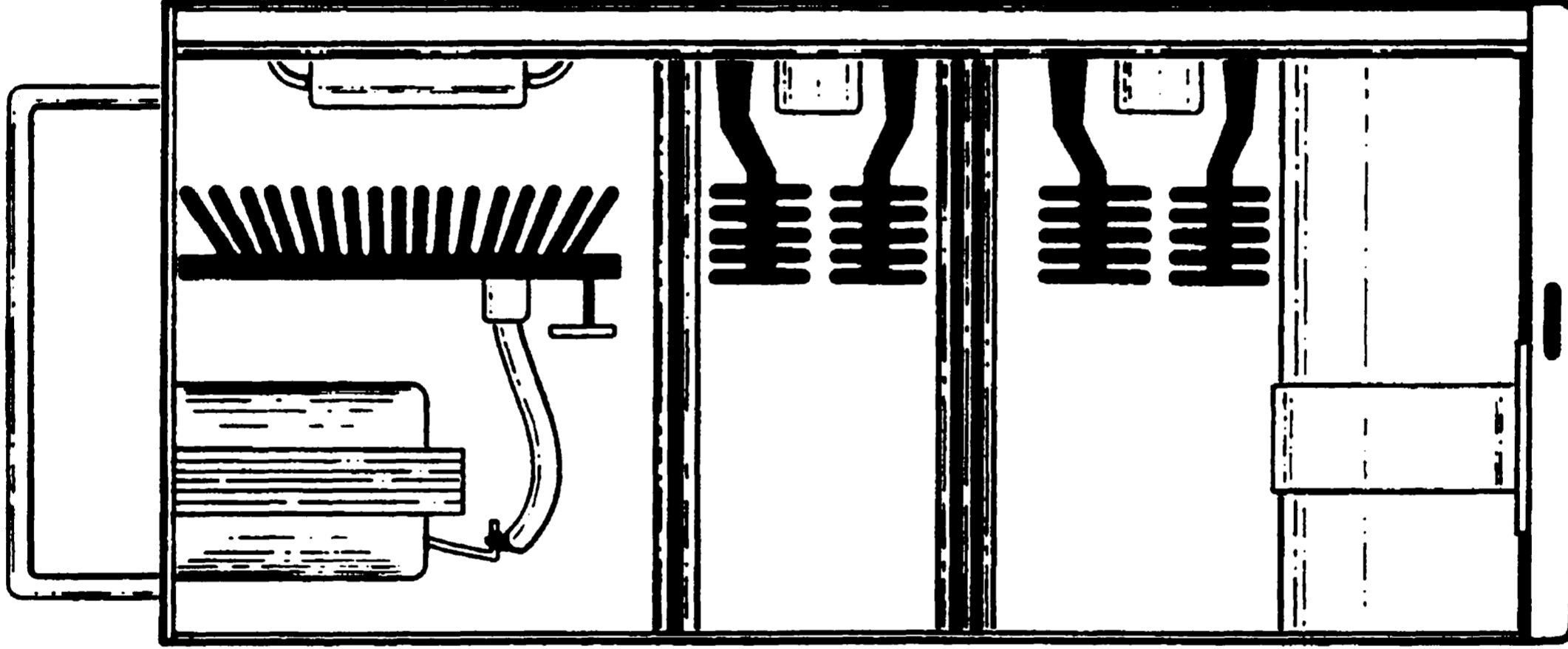

H7104D
+5V POWER SUPPLY
ASSEMBLY

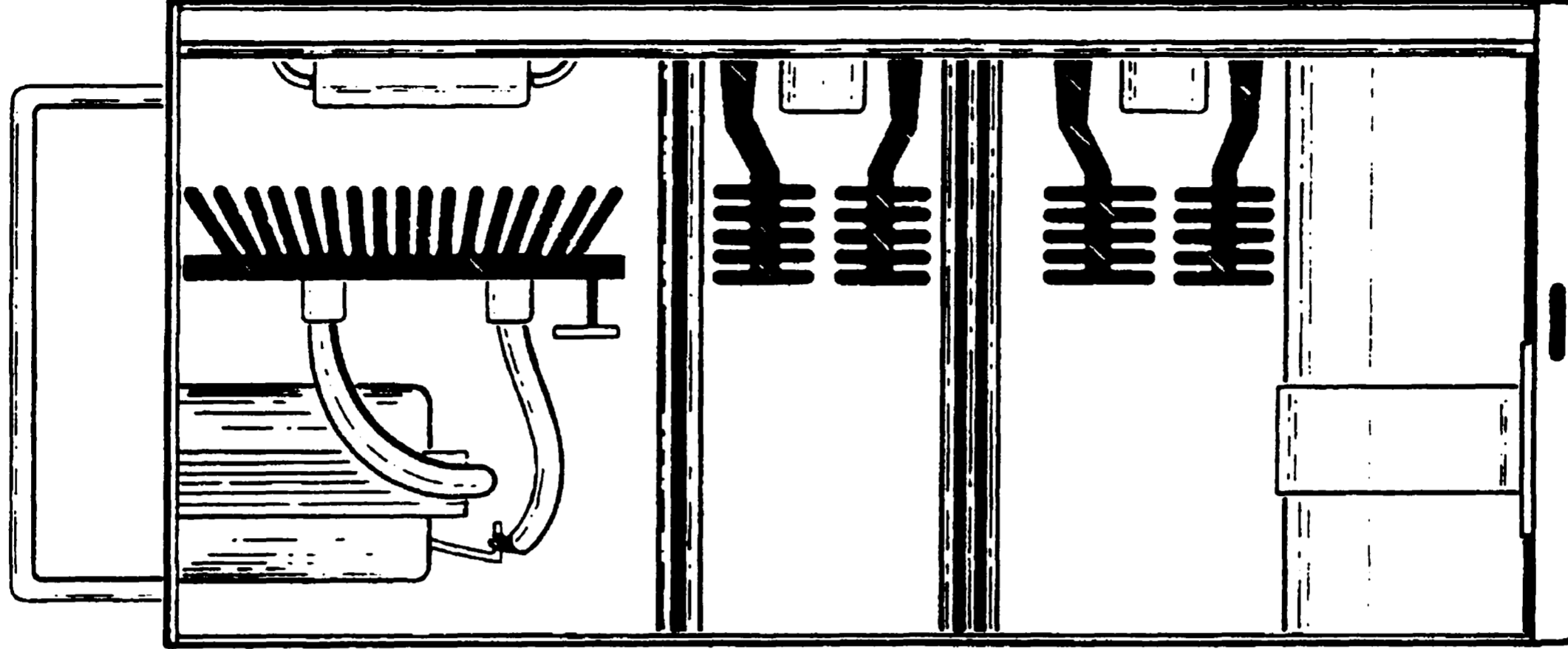

TK-5561

Figure 1-1 Outline Drawings: 875 Power Controller, H7104C +2.5 V Power Supply Assembly, and H7104D +5 V Power Supply Assembly (Sheet 1 of 2)

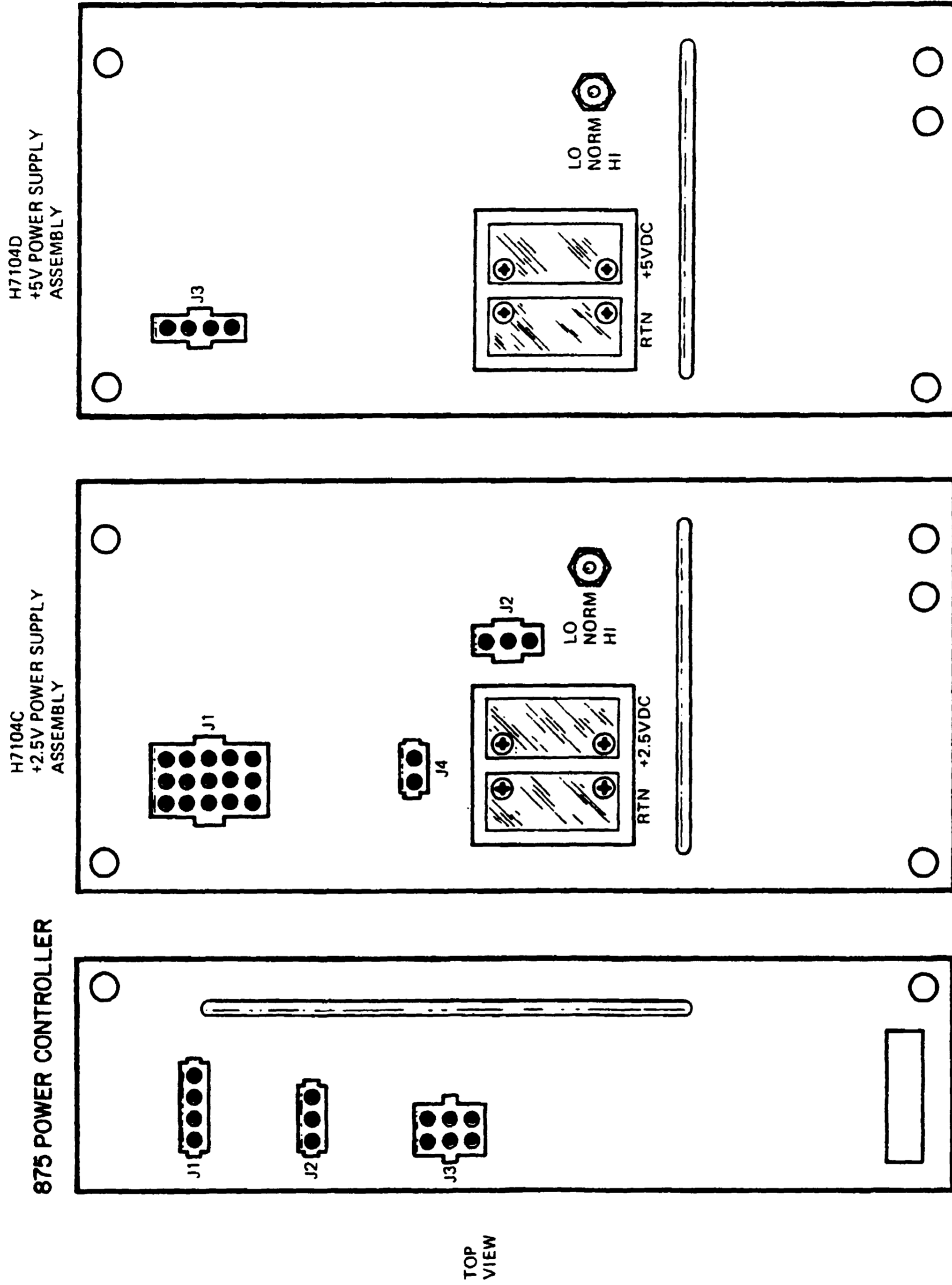

TK-5562

Figure 1-1 Outline Drawings: 875 Power Controller, H7104C +2.5 V Power Supply Assembly, and H7104D +5 V Power Supply Assembly (Sheet 2 of 2)

1.2.2 Function

The 875A and 875B power controllers (power controller) perform the following functions:

1. Control application of the ac facility power input to the ac line loads,
2. Provide overload and inrush protection for the ac line loads,
3. Provide for automatic disconnect of ac power from the line loads if an overtemperature condition or airflow problem develops,
4. Display the operational status and fault conditions of the H7104 power system,
5. Provide the interface for interconnecting the H7104 power system with remote power systems to effect sequencing powerup of remote power systems and to effect shutdown of all power systems if an overtemperature condition develops in any of the interconnected power systems.

The H7104C +2.5 V power supply assembly (+2.5 V power supply assembly) employs a switching regulator to convert the ac facility power input from the power controller to regulated +2.5 Vdc 85 A, +5 VB dc 10 A, -5 VB dc 1.2 A, and +12 VB dc 10 A outputs. (The B designation associated with the ± 5 VB and +12 VB dc outputs indicates that these voltages will be backed up by the battery backup unit, if installed as an option.)

The +2.5 V output is used in the CPU modules, the floating-point accelerator (if installed as an option), and other module options. The +5 VB output is used in the memory controller and optional memory arrays. The -5 VB output is used in the optional memory arrays and other module options. The +12 VB output is used in the optional memory arrays, the remote diagnostic module, if installed, and the UNIBUS interconnect module of the CPU.

The H7104D +5 V power supply assembly (+5 V power supply assembly) employs a switching regulator to convert the ac facility power input from the power controller to regulated +5 Vdc 135 A, +15 Vdc 2 A, and -15 Vdc 3.5 A outputs. The +5 V power supply assembly also generates the bias voltages and basic synchronization pulses used within the +2.5 V and +5 V power supply assemblies.

The +5 V output is used in all CPU modules, the floating-point accelerator (if installed as an option), the remote diagnostic module (if installed), the optional memory arrays, and all UNIBUS optional modules, and other module options. The +15 V output is used for all UNIBUS optional modules. The -15 V output is used for the UNIBUS interconnect module of the CPU, the remote diagnostic module (if installed), and the optional UNIBUS modules.

Both the +2.5 V and +5 V power supply assemblies contain fault detection circuits which drive indicators on the power controller and control panel to provide visual indications of operational status or fault condition within the H7104 power system.

The ac harness distributes the ac output from the power controller to the +2.5 V and +5 V power supply assemblies. The control cable assembly interconnects the +2.5 V and +5 V power supply assemblies to effect distribution of the bias voltages, sync pulse, and status signal outputs of the +5 V power supply assembly to the +2.5 V power supply assembly. The remote +2.5 V sense cable assembly interconnects the +2.5 V power supply assembly with the CPU backplane to effect regulation of the +2.5 Vdc output of the +2.5 V power supply assembly.

The blower motor assembly provides cooling for the modules connected to the CPU and UNIBUS option backplanes and for the +5 V and +2.5 V power supply assemblies. The airflow sensor interfaces with the power controller to effect shutdown of the H7104 power system if an airflow problem develops. The time-of-year battery provides +5 V at 6 mA to allow operation of the time-of-year clock for periods up to 100 hours during power down conditions. Two wafers of the five-position keyswitch (OFF/SECURE/LOCAL/REMOTE SECURE/REMOTE switch) on the control panel enable remote power up control of the H7104 power system and enable operation of the battery backup unit if installed. An indicator (CPU STATE/POWER) on the control panel lights to indicate that the H7104 power system is operational. The battery backup unit (H7112), if installed as an option, is used to maintain the +5 VB, -5 VB, and +12 VB dc outputs of the +2.5 V power supply assembly during power-down conditions resulting from a loss or low-level condition of the ac facility power input.

1.2.3 Controls and Indicators

The controls and indicators on the H7104 power system and related assemblies are listed in Table 1-1. The function of each of the controls and indicators is also specified in the table.

1.3 RELATED DOCUMENTATION

1.3.1 Field Maintenance Print Set

The engineering drawings of the field maintenance print set applicable to the H7104 power system and H7112 battery backup unit are specified in Table 1-2.

1.3.2 VAX-11/750 Technical Descriptions

This document and the technical descriptions listed in Table 1-3 describe the operation of the basic VAX-11/750 system.

Table 1-1 Controls and Indicators

Control or Indicator	Function(s)
Control Panel	
5-POSITION KEYSWITCH (as related to the H7104 power system)	Provides for remote power up control of H7104 power system and other power systems interconnected to the DEC power bus connectors on the power controller. When battery backup unit is installed as an option, enables battery backup unit operation when keyswitch is set at any position other than OFF. When set at OFF, inhibits battery backup unit.
CPU STATE/POWER	Lights to indicate that H7104 power system is operational (no faults).

Table 1-1 Controls and Indicators (Cont)

Control or Indicator	Function(s)
Power Controller	
OVERTEMP	Indicator disk flips (shows yellow) to indicate an overtemperature condition exists in the +2.5 V or +5 V power supply assembly.
OVERVOLTAGE	Lights to indicate an overvoltage condition exists in the +2.5 V or +5 V power supply assembly.
OVERCURRENT	Lights to indicate an overcurrent condition exists in the +2.5 V or +5 V power supply assembly.
+5 FAIL	Lights to indicate a +5 V power fault condition in the +5 V power supply assembly.
+2.5 FAIL	Lights to indicate a +2.5 V power fault condition in the +2.5 V power supply assembly.
POWER OK	Lights to indicate that the H7104 power system is operational.
REG FAIL	Lights to indicate that one of the regulators has failed, i.e., the ± 5 VB or +12 VB regulators in the +2.5 V power supply assembly or the ± 15 V regulator in the +5 V power supply assembly.
Circuit Breaker, CBI	<p>Applies ac facility power input to the ac power distribution and control circuits within the power controller.</p> <p>Provides inrush and overload protection for the ac line loads.</p>
REMOTE/OFF/LOCAL switch	
REMOTE position	Enables remote power up control of H7104 power system and any other power system connected to the DEC power bus connectors on the power controller. Remote power up control provided by 5-position keyswitch on control panel.
OFF position	Inhibits power up of H7104 power system. However, power up control of remote power systems connected to the DEC power bus connectors on the power controller can be initiated by using the 5-position keyswitch on control panel.
LOCAL position	Enables power up control of the H7104 power system and any power system connected to the DEC power bus connectors on the power controller independently of 5-position keyswitch on control panel.
POWER	Lights to indicate that the power controller is connected to the ac facility power outlet and that ac facility power input is present within the power controller (power controller is plugged in).

Table 1-1 Controls and Indicators (Cont)

Control or Indicator	Function(s)
-----------------------------	--------------------

+5 V Power Supply Assembly

HI/NORMAL/LO switch

NOTE

HI and LO positions are used only during limited testing. When set at LO, inhibits DC LO from being generated by an out-of-tolerance output from the +5 V power supply.

- | | |
|-----------------|---|
| HI position | Increases the +5 V output of the +5 V power supply by 5%. HI position is used only during limited testing to detect marginal performance of the logic that uses +5 V. |
| NORMAL position | Provides for normal regulation of the +5 V output of +5 V power supply assembly. |
| LO position | Decreases the +5 V output of the +5 V power supply by 5%. LO position is used only during limited testing to detect marginal performance of the logic that uses +5 V. |

+2.5 V Power Supply Assembly

HI/NORMAL/LO switch

NOTE

HI and LO positions are used only during limited testing.

- | | |
|-----------------|--|
| HI position | Increases the +2.5 V output of the +2.5 V power supply assembly by 5%. HI position is used only during limited testing to detect marginal performance of the logic that uses +2.5 V. |
| NORMAL position | Provides for normal regulation of the +2.5 V output of +2.5 V power supply assembly. |
| LO position | Decreases the +2.5 V output of the +2.5 V power supply assembly by 5%. LO position is used only during limited testing to detect marginal performance of the logic that uses +2.5 V. |
-

Table 1-2 Related Drawings

Title	Document Number
Cabinet Assembly, VAX-11/750	E-AD-7016707
H7104 Power System Drawing Directory	B-DD-H7104
H7104 Interconnection Diagram	E-IC-H7104
H7104 Power System Arrangement	D-UA-H7104
875A, B Controller Table of Contents	B-TC-875A, B
875A Controller Assembly Drawing	E-AD-7015929-00
875B Controller Assembly Drawing	E-AD-7015929-01
875A, B Controller Parts List	B-PL-7015929-00
Power Status Indicator Unit Assembly	D-UA-5413392-0-0
Power Status Indicator Circuit Schematic	C-CS-5413392-0-1
Pilot Control Board Unit Assembly	D-UA-5413016-0-0
Pilot Control Board Circuit Schematic	D-CS-5413016-0-1
Pilot Control Board Parts List	K-PL-5413016-00
H7104C Power Supply Table of Contents	B-TC-H7104C
+2.5 V Power Supply Assembly Drawing	E-UA-7016157-01
+2.5 V Power Supply Parts List	B-PL-7016157-0-0
Star Motherboard Unit Assembly	E-UA-5412550-0-0
Star Motherboard Circuit Schematic	D-CS-5412550-0-1
Star Motherboard Parts List	K-PL-5412550-00
+12 VB Regulator Unit Assembly	E-UA-5412556-0-0
+12 VB Regulator Circuit Schematic	D-CS-5412556-0-1
+12 VB Regulator Parts List	K-PL-5412556-00
±5 VB Regulator Unit Assembly	E-UA-5413414-0-0
±5 VB Regulator Circuit Schematic	D-CS-5413414-0-1
±5 VB Regulator Parts List	K-PL-5413414-00
+2.5 V Control Board Unit Assembly	E-UA-5413396-0-0
+2.5 V Control Board Circuit Schematic	D-CS-5413396-0-1
+2.5 V Control Board Parts List	K-PL-5413396-00
Overvoltage Card Unit Assembly	D-UA-5413559-0-0
Overvoltage Card Circuit Schematic	B-CS-5413559-0-1
Overvoltage Card Parts List	K-PL-5413559-00
Snubber Card Assembly Unit Assembly	D-UA-5413658-0-0
Snubber Card Assembly Circuit Schematic	B-CS-5413658-0-1
Snubber Card Assembly Parts List	K-PL-5413658-00
+2.5 V Output Panel Assembly Drawing	E-AD-7015857-0-0
+2.5 V Output Panel Assembly Parts List	B-PL-7015857-0-0
Bottom Panel Assembly Interconnect	D-IA-7015856-0-0
Bottom Panel Assembly Parts Lists	B-PL-7015856-0-0
H7104D Power Supply Table of Contents	B-TC-H7104D
+5 V Power Supply Assembly Drawing	E-UA-7016156-01
+5 V Power Supply Parts List	B-PL-7016156-00
Star Motherboard Unit Assembly	E-UA-5412550-0-0
Star Motherboard Circuit Schematic	D-CS-5412550-0-1
Star Motherboard Parts List	K-PL-5412550-00
H7104 Bias Control Unit Assembly	E-UA-5413382-0-0
H7104 Bias Control Circuit Schematic	D-CS-5413382-0-1
H7104 Bias Control Parts List	K-PL-5413382-00

Table 1-2 Related Drawings (Cont)

Title	Document Number
± 15 V Regulator Unit Assembly	E-UA-5413417-0-0
± 15 V Regulator Circuit Schematic	D-CS-5413417-0-1
± 15 V Regulator Parts List	K-PL-5413417-00
Overvoltage Card Unit Assembly	D-UA-5413559-0-0
Overvoltage Card Circuit Schematic	B-CS-5413559-0-1
Overvoltage Card Parts List	K-PL-5413559-00
Snubber Card Assembly Unit Assembly	D-UA-5413658-0-0
Snubber Card Assembly Circuit Schematic	B-CS-5413658-0-1
Snubber Card Assembly Parts List	K-PL-5413658-00
+5 V Output Panel Assembly Drawing	E-AD-7016151-0-0
+5 V Output Panel Assembly Parts List	B-PL-7016151-0-0
Bottom Panel Assembly Interconnect	D-IA-7015856-0-0
Bottom Panel Assembly Parts List	B-PL-7015856-0-0
H7112 Battery Backup (Optional)	
Battery Charger (H7112) Unit Assembly	E-UA-H7112-0-0
Battery Charger (H7112) Parts List	A-PL-H7112-0-0
AC Bracket Assembly Drawing	E-AD-7014122-0-0
Battery Charger Unit Assembly	D-UA-5412675-0-0
Battery Charger Parts List	K-PL-5412675-0-0
Battery Charger Circuit Schematic	D-CS-5412675-0-1
H7112 Interconnection Diagram	C-IC-H7112-0-3
Control Cable Assembly	C-IA-7016513-0-0
Remote +2.5 V Sense Cable Assembly	D-IA-7016516-0-0
AC Harness	D-IA-7016153-0-0

Table 1-3 Related Manuals

Title	Document Number
VAX-11/750 CPU Technical Description	EK-KA750-TD
VAX-11/750 Memory System Technical Description	EK-MS750-TD
VAX-11/750 UBI Technical Description	EK-UI750-TD

CHAPTER 2

POWER SYSTEM SPECIFICATIONS AND OPERATING INSTRUCTIONS

2.1 H7104A, B POWER SYSTEMS

The electrical and environmental specifications for the H7104A, B power systems are as follows:

Environmental

Temperature
Operating

10° to 50° C (50° to 122° F)

Nonoperating

−40° to 65° C (−40° to 149° F)
(exclusive of battery backup)

Although battery backup unit may be stored safely within the non-operating temperature range, it is recommended that this unit be stored at a temperature <30° C (86° F) to minimize self-discharge.

Relative Humidity
Operating

10% to 90%

Altitude
Operating

20 inches of mercury (10,000 ft)

Nonoperating

8.88 inches of mercury (30,000 ft)

Cooling

External forced air cooling at 340 ft³/minute is required.

Input Power

Voltage/Frequency
H7104A

90 to 128 Vrms/47 to 63 Hz

H7104B

180 to 256 Vrms/47 to 63 Hz

Current
H7104A

25 Arms maximum at 90 Vrms

H7104B

12.5 Arms maximum at 180 Vrms

Inrush Current

100 A peak for 1/2 cycle, decreasing exponentially over 8 cycles

Apparent Power

2300 VA maximum (i.e., 120 Vac @ 19.2 A or 240 Vac @ 9.6 A)

Power Factor	0.6 at full load and low input voltage
Noise Susceptibility	
Single transient without system degradation	300 V at 0.2 W-s maximum
Single transient survival	1000 V at 2.5 W-s maximum
Average transient power	0.5 W maximum
CW Noise	
10 KHz–3 MHz	3 Vrms maximum
3 MHz–500 MHz	1 Vrms maximum
500 MHz–1000 MHz	0.5 Vrms maximum
FR Field Susceptibility	
10 KHz–1000 MHz	1 V/m
Power Interruption Ride-Through Capability	All power supply and control outputs remain within limits for 10 ms minimum at low input voltage and full load during power fluctuations.
Overtages	
H7104A	150 Vrms for 1 s
H7104B	300 Vrms for 1 s
Undervoltages and Outages	Capable of withstanding without physical damage

Output Power and Signal Characteristics

See applicable assembly specifications:

- 875A, B Power Controllers – Paragraph 2.1.1
- H7104C +2.5 V Power Supply – Paragraph 2.1.2
- H7104D +5 V Power Supply – Paragraph 2.1.3

2.1.1 875A, B Power Controller Assemblies

The specifications for the 875A, B power controller assemblies are as follows:

Input Protection

Circuit Breaker Rating	
875A	25 A ac output to H7104C and H7104D power supply assemblies 5 A ac output to ac outlets 30 A neutral

875B	12.5 A ac output to H7104C and H7104D power supply assemblies 2.5 A ac output to ac outlets 15 A neutral
------	--

Fuse	0.12 A fuse protects the power control transformer.
------	---

Thermostat	Closes at 71° C (160° ± 7° F); automatically resets at 49° C (120° ± 15° F)
------------	---

AC Outputs

AC Outlets (4)	
875A	120 Vac, 5 A
875B	240 Vac, 2.5 A

NOTE

AC outlets are intended only for use inside the cabinet. No external loads are to be connected to the power controller.

AC Bus (15-pin connector on lower rear portion of power controller)

875A	120 Vac, 25 A
875B	240 Vac, 12.5 A

Control Signal Inputs

Airflow Shutdown	Asserted, low-level signal (GND); deasserted, open
------------------	--

Overtemp Shutdown	Asserted, low-level signal (GND); deasserted, open
-------------------	--

Remote Power Supply Enable	Asserted, low-level signal (GND); deasserted, open
----------------------------	--

Control Signal Outputs

Overtemp Shutdown	Asserted, low-level signal (GND); deasserted, open
-------------------	--

Normal Power Up Request	Asserted, low-level signal (GND); deasserted, open
-------------------------	--

Delayed Power Up Request	Asserted 1/2 s after normal power up request, low-level signal (GND); deasserted, open
--------------------------	--

Switched +15 V	+15 V
----------------	-------

2.1.2 H7104C +2.5 V Power Supply Assembly

The specifications for the H7104C +2.5 V power supply assembly are as follows:

Input Protection

Fuse 0.12 A slow blow (located on bottom panel assembly)

Overtemperature Protection

Thermal Switch Closes at 100° C (212° ±8° F); automatically resets at 80° C (177° ±10° F)

DC Outputs

+2.5 V Output

Current 8.5 A minimum to 85 A maximum

Total Regulation ±5%

Static Line and
Static Load
Regulation ±3%

Dynamic Load
Regulation Maximum overshoot <100 mV
 $\Delta I = 8.5 \text{ A}$
 $\Delta I / \Delta T = 0.5 \text{ A}/\mu\text{s}$

Settling time ≤4 ms

Overcurrent 105 A (±15%), fold back to 2 Arms

Overvoltage 3.3 V maximum, crowbar protected

HI/NORM/LO Switch Switch allows +2.5 V output to be increased or decreased by 5%. These ±5% modes are used for test purposes only. Regulation of the increased or decreased output voltage is maintained at ±5% of selected value.

±5 VB

Current +5 VB, 2 A minimum to 20 A maximum*

−5 VB, 0.0 A minimum to 1.2 A maximum

Total Regulation ±5%

Static Line and
Load Regulation ±3%

*Nominal current is 10 A (50 W). Each additional watt drawn from the +5 VB regulator requires a decrease of 1 W drawn from the +12 VB regulator. (See Table 4-3 for dc power requirements.)

Dynamic Load Regulation

Maximum overshoot <100 mV
Settling time
+5 VB, <50 ms
-5 VB, <4 ms
 $\Delta I = 10\%$ of full load
 $\Delta I / \Delta T = 0.5 \text{ A}/\mu\text{s}$

Overcurrent

+5 VB, 24 A ($\pm 10\%$), fold back to 2 A
-5 VB, 1.44 A ($\pm 10\%$), short circuit current 2.2 A

Overvoltage

Crowbar protected
+5 VB, 6.8 V maximum
-5 VB, -6.8 V maximum

+12 VB

Current

1 A minimum to 10 A maximum

Total Regulation

$\pm 5\%$

Static Line and Load Regulation

$\pm 3\%$

Dynamic Load Regulation

Maximum overshoot <150 mV
Settling time <4 ms
 $\Delta I = 1 \text{ A}$
 $\Delta I / \Delta T = 0.5 \text{ A}/\mu\text{s}$

Overcurrent

12 A ($\pm 10\%$), fold back to 2.5 A limit

Overvoltage

15 V maximum, crowbar protected

Control Signal Outputs

AC LO

Asserted, low-level signal with sink capability of 50 mA at 400 mV; deasserted, high-impedance signal with no drive capability

DC LO

Asserted, low-level signal with sink capability of 50 mA at 400 mV; deasserted, high-impedance signal with no drive capability

Battery Backup Enable

Asserted, GND level signal; deasserted, -12 Vdc

2.1.3 H7104D +5 V Power Supply Assembly

The specifications for the H7104D +5 V power supply assembly are as follows:

Input Protection

Fuse

0.12 A slow blow (located on bottom panel assembly)

Overtemperature Protection

Thermal Switch

Closes at 100° C (212° $\pm 8^\circ$ F); automatically resets at 80° C (177° $\pm 10^\circ$ F)

DC Outputs

+5 V Output

Current	10 A minimum to 135 A maximum
Total regulation	$\pm 5\%$
Static Line and Load Regulation	$\pm 3\%$
Dynamic Load Regulation	Maximum overshoot < 300 mV Settling time < 4 ms $\Delta I = 13.5$ A $\Delta I / \Delta T = 0.5$ A/ μ s
Overcurrent	155 A ($\pm 10\%$), fold back to 2 Arms
Overvoltage	6.8 V maximum, crowbar protected
HI/NORM/LO Switch	Switch allows +5 V output to be increased or decreased by 5%. These $\pm 5\%$ modes are used for test purposes only. Regulation of the increased or decreased output voltage is maintained at $\pm 5\%$ of selected value.

± 15 V Outputs

Current	+15 V, 0.2 A minimum to 2 A maximum -15 V, 0.35 A minimum to 3.5 A maximum
Total Regulation	$\pm 5\%$
Static Line and Load Regulation	$\pm 2\%$
Dynamic Load Regulation	Maximum overshoot ≤ 450 mV Settling time < 10 ms $\Delta I = 10\%$ of full load $\Delta I / \Delta T = 0.5$ A/ μ s
Overcurrent	+15 V, 2.4 A ($\pm 10\%$), fold back to 1.5 A limit -15 V, 4.2 A ($\pm 10\%$), fold back to 1.5 A limit
Overvoltage	Crowbar protected -15 V, +18 V maximum -15 V, -18 V maximum

2.2 OPERATING INSTRUCTIONS

2.2.1 Turn-On Procedure

1. Make certain the five-position keyswitch on the control panel is set at OFF.
2. Set HI/NORM/LO switches on top of +2.5 V and +5 V power supply assemblies at NORM.
3. Set REMOTE/OFF/LOCAL switch on power controller at REMOTE.
4. Set circuit breaker CBI on power controller at ON.
5. If battery backup unit is installed as an option, set POWER ON/OFF switch on battery backup unit at ON.
6. Set five-position keyswitch on control panel at desired position.

2.2.2 Turn-Off Procedure

NOTE

If five-position keyswitch on the control panel is left on and circuit breaker on power controller is set at OFF, the battery backup unit, if installed as an option, will be turned ON.

1. Set five-position keyswitch on the control panel at OFF.
2. Set circuit breaker CBI on power controller at OFF.

CHAPTER 3

MECHANICAL CONFIGURATION AND CABLING

3.1 MECHANICAL CONFIGURATION

Engineering drawing 7016707 illustrates the relative location of the H7104 power system assemblies and related cables and assemblies within the VAX-11/750 cabinet assembly. The major assemblies comprising the H7104 power system are identified in engineering drawings 7016157, 7016156, and 7015929.

3.1.1 H7104C +2.5 V Power Supply Assembly

Engineering drawing 7016157 illustrates the physical relationship between the major components of the H7104C +2.5 V power supply assembly. The major components include a bottom panel assembly (item 2), a motherboard (3), two regulator assemblies (9 and 10), a +2.5 V control board (4), and an output panel assembly (1). As illustrated, the interface between the +2.5 V control board (4), ± 5 V regulator (9), +12 V regulator (10), and motherboard (3) is provided by motherboard connectors J3 and J4, J1, and J2, respectively. The interface between the motherboard (3) and the bottom panel assembly (2) is provided by terminal board TB1 and connector J5 on the motherboard. Additionally, the capacitors secured to the bottom panel assembly (2) are electrically and physically mated to the motherboard with screws. The interface between the output panel assembly (1) and the motherboard is effected via TB2 on the motherboard. Internal cabling within the +2.5 V power supply assembly is also illustrated in drawing 7016157.

3.1.2 H7104D +5 V Power Supply Assembly

The physical relationship between the major components of the H7104D +5 V power supply assembly is illustrated in engineering drawing 7016156. As shown, the major components include a bottom panel assembly (item 2), a motherboard (3), a regulator assembly (9), 5 V control board (4), and an output panel assembly (1). The interface between the motherboard (3), the +5 V control board (4), and regulator assembly (9) is provided by motherboard connectors J3 and J4, and J1, respectively. The interface between the bottom panel assembly (2) and the motherboard is provided by TB1 and J5 on the motherboard. Additionally, the capacitors secured to the bottom panel assembly are electrically and physically mated to the motherboard with screws. The interface between the output panel assembly (1) and the motherboard is effected via TB2 on the motherboard. Internal cabling within the +5 V power supply assembly is also illustrated in drawing 7016156.

3.1.3 875A, B Power Controller Assemblies

The physical locations of the major components comprising the 875A, B power controllers are illustrated in engineering drawing 7015929. As shown, the major components include a power cord assembly (item 47 or 48), line filter (18), circuit breaker (23 or 24), contactor assembly (7 or 21), transformer assembly (14), pilot control board (12), and status indicator board (11). Engineering drawing 7015929 also illustrates the internal cabling within the power controller.

3.2 CABLING

Cabling data for the H7104 power system and related assemblies are presented in engineering drawing 7016707. The cabling diagrams of 7016707 illustrate the relative location of assembly connectors and cable routing. Cabling for distribution of ac and dc power, airflow sense, temperature sense, bias voltages, control signals, status display signals, and grounding is discussed in paragraphs 3.2.1 through 3.2.9. An overall cabling diagram is presented also in 7016707.

3.2.1 AC Power Distribution

The cabling required to interconnect the power controller with the ac facility power input and to distribute the controlled ac power outputs of the power controller to the ac line loads is illustrated in engineering drawing 7016707. The ac line cord which is part of the power controller interconnects the power controller with the ac facility power outlet. The ac line loads connected to the power controller are the +2.5 V power supply assembly, the +5 V power supply assembly, the blower assembly, and the battery backup unit (if installed as an option).

Distribution of controlled ac power from the power controller to the +2.5 V and +5 V power supply assemblies is effected by the ac harness (7016153-00) (item 57). P1 of the ac harness connects to the 15-pin connector on the back of the power controller. P2 and P3 of the ac harness connect to the 15-pin connectors on the back of the +2.5 and +5 V power supply assemblies, respectively.

Controlled ac power for the blower assembly is available at one of the four ac outlets on the back of the power controller. The controlled ac power from the power controller is routed to the blower assembly via blower cable (7016908-00, item 63, when 115 Vac is used as input, or 7016908-01, item 70, when 230 Vac is used as input).

Controlled ac power for the battery backup unit is available at one of the four ac outlets on the back of the power controller. The cable assembly used to route the ac power to the battery backup unit is part of the battery backup unit.

3.2.2 DC Power Distribution

3.2.2.1 DC Power Distribution to CPU Backplane – The cable interconnections and routing relative to the distribution of the dc power outputs of the H7104 power system to the loads are illustrated in engineering drawing 7016707.

The 5 Vdc output of the time-of-year (TOY) battery is coupled to the CPU backplane connector (J5) via a cable which is part of the TOY battery (item 20).

The +5 V, 135 A dc output and +5 V return from the +5 V power supply assembly are interconnected with the CPU backplane via power cable assemblies 7016938-02 and 7016938-03, respectively. Cable assemblies 7016938-02 and 7016938-03 are secured to the +5 V power supply assembly output bus bars by Phillips head screws with captive lock washers at 22 inch-pounds of force. The +5 V and +5 V return power cable assemblies are secured to studs on the CPU backplane with captive lock washers and nuts at 22 inch-pounds of force. The location of the +5 V and +5 V return bus studs on the backplane are labeled K and L, respectively, in engineering drawing 7016707.

The +2.5 V, 85 A dc output and +2.5 V return from the +2.5 V power supply assembly are interconnected with the CPU backplane via power cable assemblies 7016938-01 and 7016938-00, respectively. These cable assemblies are secured to the +2.5 V power supply assembly output bus bars by Phillips head screws with captive lock washers at 22 inch-pounds of force. The +2.5 V and +2.5 V return cable assemblies are secured to studs on the CPU backplane with captive lock washers and nuts at 22 inch-pounds of force. The studs on the CPU backplane to which the +2.5 V and +2.5 V return cable assemblies connect are labeled G(1 and 2) and H(1 and 2), respectively, in engineering drawing 7016707.

The +2.5 Vdc output of the +2.5 V power supply assembly is sampled at the CPU backplane and is routed back to the +2.5 V power supply where it is used for regulation of the +2.5 V output. The +2.5 Vdc level from the CPU backplane is interconnected to the +2.5 V power supply assembly via the remote +2.5 V sense cable assembly 7016516-00. The red and black terminal rings of the remote +2.5 V sense cable assembly are secured to studs labeled G-3 and H-3, respectively, in engineering drawing 7016707. P1 of the remote +2.5 V sense cable assembly connects to J4 of the +2.5 V power supply assembly.

The +15 V, 2 A and -15 V, 3.5 A dc outputs of the +5 V power supply assembly and the +5 VB, 20 A, -5 VB, 1.2 A, and +12 VB, 10 A outputs of the +2.5 V power supply assembly are distributed to the loads via the power signal harness 7016385-00.

NOTE

The power signal harness 7016385-00 is also used to distribute the AC LO and DC LO signal outputs of the +2.5 V power supply assembly to the CPU and UNIBUS backplanes. The distribution of the AC LO and DC LO signals is discussed in paragraph 3.2.6.

The ± 15 V outputs from J3 of the +5 V power supply assembly and the ± 5 VB and +12 VB outputs from J1 of the +2.5 V power supply assembly are distributed to CPU backplane connectors J1 and J3. This distribution is effected by the power signal harness (7016385-00). P4 of the power signal harness (7016385-00) connects to J3 on the top of the +5 V power supply assembly. P1 of the power signal harness connects to J1 on the +2.5 V power supply assembly. P2 and P3 of the power signal harness connect to CPU backplane connectors J3 and J1, respectively.

3.2.2.2 DC Power Distribution to UNIBUS Option Backplane and TU58 Control Board – The +5 V and ± 15 Vdc outputs of the +5 V power supply assembly are distributed to the UNIBUS option backplane (DD-11/DK) via the power option harness (7016386-00). The cable connections and routing of the power option harness are illustrated in engineering drawing 7016707. Terminal rings E2 and E3 of the power option harness connect to the CPU backplane +5 V bus lugs labeled N2 and N1, respectively. Terminal rings E4 and E5 connect to the CPU backplane ground bus lugs labeled M1 and M2, respectively. The terminal rings of the power option harness are secured to the CPU backplane bus lugs with star washers and nuts at 22 inch-pounds of force. Plug P1 of the power option harness connects to J2 of the CPU backplane. The +5 V from the CPU backplane +5 V bus and the ± 5 V from CPU backplane connector J2 are distributed to the UNIBUS option backplane connectors P2 and P4 via power option harness connectors J2 and J1, respectively.

DC power is distributed to the TU58 control board from the CPU backplane via the TU58 cable assembly (7016931-00). The connections and routing of the TU58 cable assembly used for power distribution are illustrated in engineering drawing 7016707. P3, a 22-pin connector of the TU58 cable assembly, connects to the even-numbered CPU backplane pins 2 through 44 of slot 6, section B. +5 V, +12 VB and ground available at slot 6, section B of the CPU backplane are distributed to J1 on the TU58 control board via P1 of the TU58 cable assembly.

3.2.3 Airflow Sense

The cabling required to interconnect the airflow sensor and the power controller is illustrated in engineering drawing 7016707. The switched +15 V output of the power controller is applied to the airflow sensor and the airflow shutdown output of the airflow sensor is applied to the power controller via the airflow patch cable (7016928-00). P1 of the airflow patch cable connects to J1 of the power controller and J1 of the airflow patch cable connects to P1 of the airflow sensor.

3.2.4 Temperature Sense

Temperature sensors of the H7104 power system are located in the +5 V power supply assembly, +2.5 V power supply assembly, and the power controller. The H7104 power system is configured such that an overtemperature condition in the power controller, +2.5 V power assembly, or +5 V supply assembly effects shutdown of the H7104 power system and battery backup unit, if installed as an option, by control circuitry in the power controller. The temperature sensors of the power controller, +2.5 V power supply assembly, and +5 V power supply assembly are interconnected via the control cable assembly (7016513-00) and the status cable assembly (7016514-00). The control cable assembly interconnects J1 of the +5 V control board within the +5 V power supply assembly with J1 of the +2.5 V control board within the +2.5 V power supply assembly. The status cable assembly interconnects J4 of the +2.5 V control board within the +2.5 V power supply assembly with J1 on the status board within the power controller.

The overtemperature shutdown signal output of the power controller is applied to the battery backup unit by way of the battery backup harness (7016379-00).

Additionally, the temperature sense may be extended to include power systems remote to the H7104 power system. The DEC power bus connectors, J9 and J10, on the power controller provide the means to interconnect the temperature sense lines of the H7104 power system with remote power systems. This interconnection provides for total shutdown of all power systems should an overtemperature condition develop in any one of the systems.

3.2.5 Distribution of Power Supply Bias Voltages

The bias voltages used throughout the H7104 power system are generated in the +5 V power supply assembly. The bias voltages, designated +5 VA, +12 VA, and -12 VA, are distributed to the +2.5 V power supply assembly and the power controller by way of the control cable assembly (7016513-00) and the status cable assembly (7016514-00). The routing of the control cable assembly and status cable assembly is illustrated in engineering drawing 7016707.

3.2.6 Control Signal Distribution

The control signals generated within the H7104 power system include AC LO, DC LO, BATTERY BACKUP ENABLE, and NORMAL and DELAYED POWER UP REQUEST. The H7104 power system and battery backup unit receive control signals (i.e., POWER SUPPLY REMOTE ENABLE and BBU REMOTE DISCONNECT) from the control panel assembly.

NOTE

The control signal distribution and cable routing applicable to the battery backup unit are discussed in Paragraph 3.2.8.

The AC LO and DC LO outputs at J2 of the +2.5 V power assembly are routed to the CPU backplane connector J4 and the UNIBUS option backplane connectors J1 and P3 via the power signal harness (7016385-00). P5 of the power signal harness connects to J2 of the +2.5 V power supply assembly. P6 of the power signal harness connects to CPU backplane connector J4. The UNIBUS option backplane connector J1 is part of the power signal harness and provides the AC LO and DC LO signal outputs of the H7104 power system at the UNIBUS option backplane. The AC LO and DC LO signals are jumpered from UNIBUS option backplane connector J1 to J2 of the power signal harness. J2 of the power signal harness connects to UNIBUS option backplane connector P3.

The POWER SUPPLY REMOTE ENABLE input to the H7104 power system is initiated with the five-position keyswitch (OFF, SECURE, LOCAL REMOTE/SECURE, REMOTE) on the control panel. The POWER SUPPLY REMOTE ENABLE signal is coupled to the H7104 power system by way of the console power cable assembly (7016930-00). P2 of the console power cable assembly connects to J2 of the control panel. P3 of the console power cable assembly connects to J3 of the H7104 power system power controller.

The NORMAL and DELAYED POWER UP REQUEST signal outputs of the H7104 power system are available for interconnection of the H7104 power system with remote power systems at the DEC POWER BUS/DELAYED and NORMAL connectors of the power controller.

3.2.7 Status Display Signals

The status display signals which drive the status indicators on the power controller are distributed via the control cable assembly (7016513-00) and status cable assembly (7016514-00). The control cable assembly interconnects J1 of the +5 V control board within the +5 V power supply assembly with J1 of the +2.5 V control board within the +2.5 V power supply assembly. The status cable assembly interconnects J4 of the +2.5 V control board within the +2.5 V power supply assembly with J1 on the status board within the power controller.

The status display signal which drives the CPU STATUS/POWER indicator on the control panel is distributed from the H7104 power system to the control panel via the console power cable assembly (7016930-00). The console power cable assembly interconnects J3 of the power controller with J2 of the control panel. P3 of the console power cable assembly connects to J3 of the power controller and P2 of the console power cable assembly connects to J2 of the control panel.

3.2.8 Battery Backup Unit Cabling

The battery backup unit, if installed as an option, obtains ac power from an ac power outlet on the back of the power controller. Control signal inputs to the battery backup unit and the dc voltage outputs of the battery backup unit are distributed by the battery backup harness (7016379-00). The cabling required to interconnect the battery backup unit with the H7104 power system is illustrated in engineering drawing 7016707.

The control signal inputs to the battery backup unit are the BBU REMOTE DISCONNECT, BATTERY BACKUP ENABLE, and OVERTEMP SHUTDOWN. The BBU REMOTE DISCONNECT is initiated by the five-position keyswitch (OFF, SECURE, LOCAL REMOTE/SECURE, REMOTE) on the control panel. The BBU REMOTE DISCONNECT signal is routed to the battery backup unit by way of the console power cable assembly (7016930-00), the power controller, the battery backup harness (7016379-00), and the battery backup cable (7014547-00), which is part of the battery backup unit. The console power cable assembly interconnects J2 of the control panel with J3 of the power controller. From the power controller, the BBU REMOTE DISCONNECT along with the BATTERY BACKUP ENABLE signal output of the H7104 power system are routed from the 9-pin connector on the lower back portion of the power controller to the battery backup unit by way of the battery backup harness and the battery backup cable. The battery backup harness interconnects the 9-pin connector on the lower back portion of the power controller with P1 of the battery backup cable. P2 of the battery backup cable connects to J7 on the battery backup unit. (J7 on the battery backup unit is located on the battery charger board inside the battery backup unit.)

The OVERTEMP SHUTDOWN output from J2 on the power controller is routed to the battery backup unit by way of the battery backup harness (7016379-00). The battery backup harness interconnects J2 of the power controller with one of the two 3-pin connectors on the bottom portion of the battery backup unit.

CHAPTER 4 FUNCTIONAL THEORY OF OPERATION

4.1 H7104 POWER SYSTEM

The H7104 power system and associated assemblies (Figure 4-1) are enabled by the five-position key-switch on the control panel assembly when the power controller REMOTE/OFF/LOCAL switch is in the REMOTE position. The H7104 power system may be enabled independently of the five-position keyswitch by setting the REMOTE/OFF/LOCAL switch to the LOCAL position.

The power controller controls application of the 115/230 Vac facility power to the +2.5 V and +5 V power supply assemblies, the blower motor assembly, and the battery backup unit (if installed). The power controller provides overload and inrush protection for the ac line loads and provides for automatic disconnect of ac power from the line loads if an overtemperature condition or airflow problem develops. Indicators on the power controller display the operational status and fault conditions of the H7104 power system. Additionally, the power controller provides the interface for interconnecting the H7104 power system with remote power systems. This interface (DEC POWER BUS/NORMAL and DELAYED connectors) provides for sequencing powerup of remote power systems and for effecting shutdown of all power systems if an overtemperature condition develops in any of the interconnected power systems.

The +5 V power supply assembly uses the ac power input from the power controller to generate the regulated +5 V, +15 V, and -15 V dc voltages applied to the CPU backplane. The +5 V power supply assembly also generates the bias control voltages and basic synchronization pulses (20 kHz clock) used within the +5 V and +2.5 V power supply assemblies.

The +2.5 V power supply assembly uses the ac power input from the power controller to generate the +2.5 V, +5 VB, -5 VB and +12 VB dc voltages applied to the CPU backplane.

NOTE

The B designations associated with the +5 VB, -5 VB, and +12 VB outputs of the +2.5 V power supply assembly indicate that these voltages are backed up by the battery backup unit, if installed.

When the battery backup unit is installed, the 27 to 47 Vdc output of the battery backup unit is used within the +2.5 V power supply assembly to maintain the +5 VB, -5 VB, and +12 VB dc outputs for a minimum of 10 minutes following a power-down condition resulting from a loss or low-level condition of the 115/230 Vac facility power.

NOTE

This can be simulated by powering up the system and then setting CB1 on the power controller at OFF.

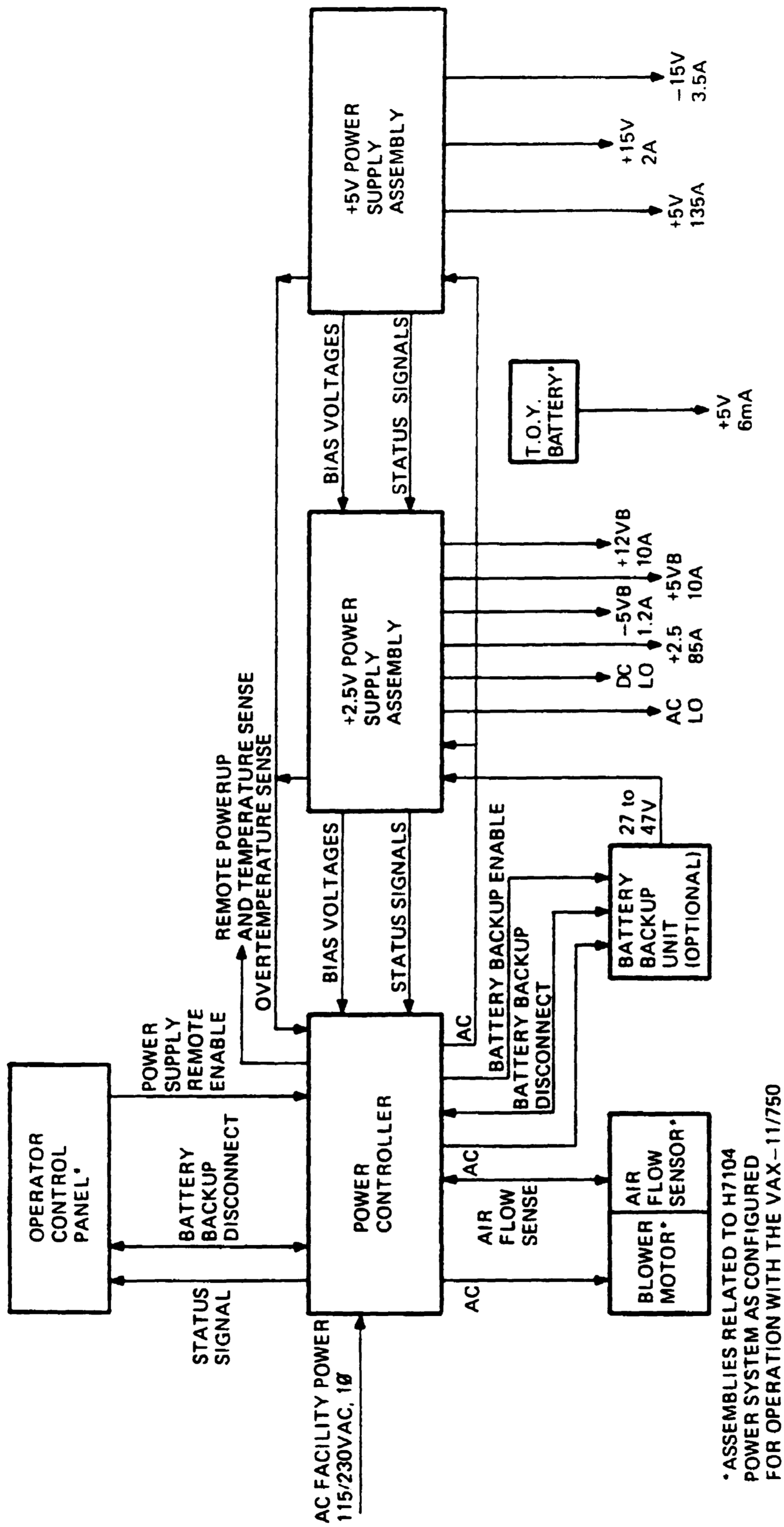

TK-5545

Figure 4-1 H7104 Power System Block Diagram

Both the +5 V and +2.5 V power supply assemblies contain fault detection circuits which automatically inhibit the applicable dc voltage outputs in case of an overvoltage or overcurrent fault or from loss or low-level condition of the 115/230 Vac facility power. The fault detection circuits drive indicators on the power controller and control panel to provide visual indications of operational status or fault condition. Additionally, the fault detection circuits generate control signals (AC LO, DC LO, and BATTERY BACKUP ENABLE) if a facility power loss or low-level condition is detected or if any of the power supplies malfunction. The AC LO and DC LO signals are applied to the CPU and UNIBUS option backplanes, and remote jacks. The BATTERY BACKUP ENABLE signal activates the battery backup unit.

To provide a cohesive functional theory of operation, the circuitry of the H7104 power system and associated assemblies is discussed by operational function. Supportive functional diagrams illustrate the physical circuit properties (i.e., the location and identification of associated components) and electrical interconnection of the components involved in performing each operational function. Table 4-1 specifies the operational functions and denotes the major assemblies involved in performing each operational function.

Table 4-1 Operational Functions and Related Assemblies

Operational Function	H7104 Power System and Related Assemblies
AC power distribution and control	Power controller +5 V power supply assembly +2.5 V power supply assembly Control panel Airflow sensor
AC input, raw dc, and H7104 bias voltage power supply	+5 V power supply assembly
+5 V power supply	+5 V power supply assembly
+15 V regulator	+5 V power supply assembly
AC input, raw dc, and +2.5 V power supply	+2.5 V power supply assembly
±5 VB regulator	+2.5 V power supply assembly
+12 VB regulator	+2.5 V power supply assembly
Fault detect and status display	+5 V power supply assembly +2.5 V power supply assembly Power controller Control panel
Time-of-year battery	Time-of-year battery
Battery backup	Battery backup unit

4.2 AC POWER DISTRIBUTION AND CONTROL

The ac power distribution and control circuitry of the H7104 power system performs the following functions.

1. It filters the 115/230 V, single-phase, ac facility power input.
2. It illuminates an indicator lamp to provide a visual indication that ac facility power is present.
3. It provides inrush and overload protection for the ac line loads connected to the power controller.
4. It controls distribution of primary ac power to the ac line loads.
5. It provides the interface to allow power-up control of remote power systems and to provide for automatic shutdown of all power systems if an overtemperature condition develops. It also provides visual indication of overtemperature condition in +2.5 V or +5 V power supply assemblies.
6. It automatically initiates power shutdown of the H7104 power system if an airflow problem develops.

Figure 4-2 is a functional block diagram of the ac power distribution and control circuitry. This diagram illustrates the electrical interface between the H7104 power system components and associated assemblies (i.e., the airflow sensor and control panel) which are related to the ac power distribution and control function. There are several differences between the 120 V (875A) and 240 V (875B) power controllers. However, the following functional description for the ac power distribution and control circuitry is applicable to both the 120 V and 240 V power controllers. The following description is keyed to Figure 4-2 and engineering drawings 7015929, 5413016, 5413392, 7016157, 5413396, 7016156, 5413382 and E-IC-H7104.

As shown in Figure 4-2, the main in-line ac components are the line filter (LF1), circuit breaker (CB1), and contactor (K1). An indicator (POWER) is attached phase-to-neutral across the output of LF1. This indicator lights to indicate the presence of the primary power source at the output of LF1 whenever the power cord assembly is connected to the facility power outlet and facility power is present. LF1 filters the ac facility power input to remove high frequency components from the primary power source. Three of the CB1 poles provide overload and inrush protection for the ac line loads. A fourth pole on CB1 provides for controlled tripping of the circuit breaker. Contactor (K1) couples the primary power to the ac outlets on the power controller and to the ac power bus for application to the +5 V and +2.5 V power supply assemblies. The trip coil of CB1 and the operation of K1 are controlled by the pilot control board.

The pilot control board is used to energize contactor K1 upon receipt of a POWER UP REQUEST signal input, and to de-energize K1 if an overtemperature condition or airflow problem develops. Additionally, the pilot control board is used to generate a DELAYED POWER REQUEST signal which may be used to sequence powerup of a remote power system. The operation of the circuitry used to control CB1 and K1, and to generate the DELAYED POWER REQUEST signal is discussed in the following paragraphs.

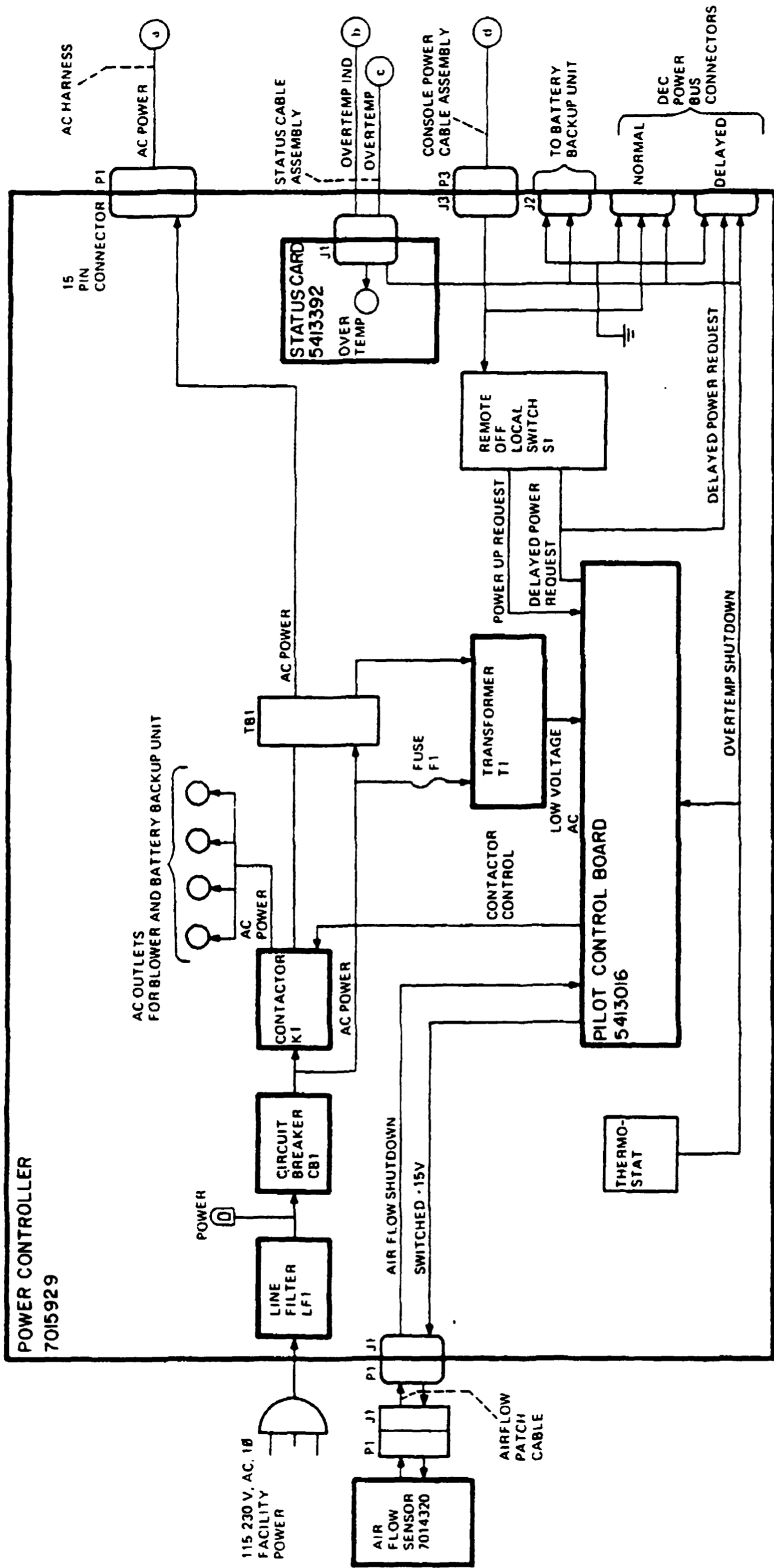

Figure 4-2 AC Power Distribution and Control Functional Block Diagram (Sheet 1 of 2)

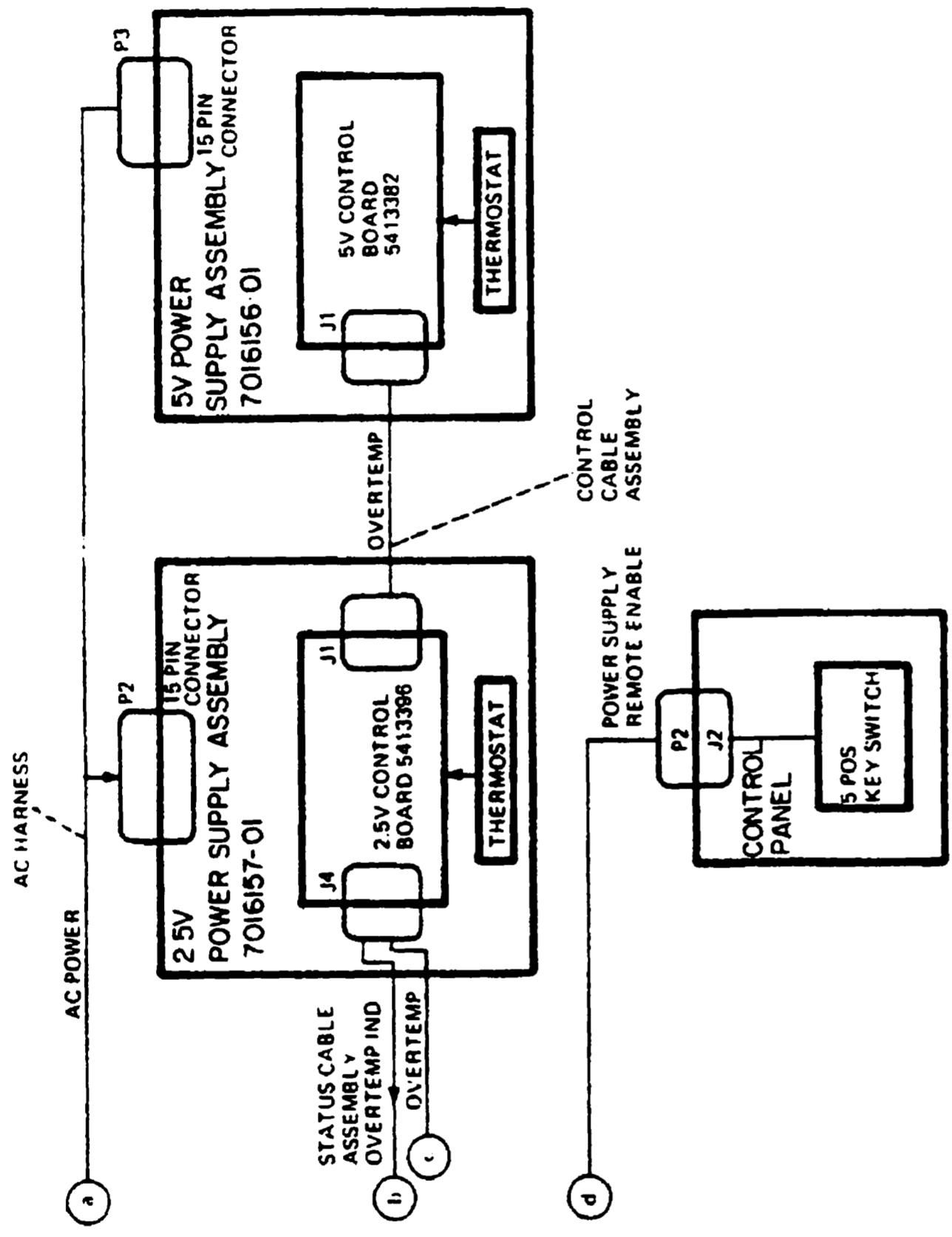

Figure 4-2 AC Power Distribution and Control Functional Block Diagram (Sheet 2 of 2)

When CB1 is closed, primary power is routed to the primary of the ac transformer (T1). The ac signal output from the secondary of T1 is rectified and filtered on the pilot control board to produce +25 Vdc. The +25 Vdc output is applied to a regulator to produce +15 Vdc. The +25 V and +15 Vdc levels are the operating voltage levels used by the pilot control board to effect control of CB1, K1, and the DELAYED POWER REQUEST output. During normal operation, the REMOTE/OFF/LOCAL switch on the power controller is set at REMOTE, and power-up control of the H7104 power system is effected using the five-position keyswitch on the control panel. When the five-position keyswitch is set to SECURE, LOCAL, REMOTE/SECURE, or REMOTE, chassis ground (POWER SUPPLY REMOTE ENABLE) is coupled through the REMOTE/OFF/LOCAL switch on the power controller and is applied to the pilot control board. The POWER SUPPLY REMOTE ENABLE signal is applied also to the DEC POWER BUS NORMAL connector. The signal input at the pilot control board (POWER UP REQUEST) enables the current paths which activate the 1/2-second delay (Q3, D5, D8, D12, E2), the 15 V switch (Q1, Q2, E1, D11), and the solid state switch (K1). The POWER UP REQUEST signal is also applied to the 15 V sense (D9, D10, Q4, K1).

The POWER UP REQUEST input initiates generation of the DELAYED POWER REQUEST output, switching of +15 V to the airflow sensor, and closure of the current path which causes contactor (K1) to energize, distributing the primary power to the ac line loads.

The 1/2-second delay and the 15 V sense circuits control the DELAYED POWER REQUEST output applied to the DEC POWER BUS/DELAYED connector. The 1/2-second delay initiates the DELAYED POWER REQUEST output, 1/2 second after the POWER UP REQUEST is applied. The 15 V sense circuit maintains the DELAYED POWER REQUEST output if the output of the 15 V regulator drops below 12 V (i.e., during an automatic power-down condition of the H7104 power system). The output is maintained by coupling the POWER UP REQUEST input signal to the DELAYED POWER REQUEST output by way of normally closed relay contacts in the 15 V sense circuit.

The 15 V switch (E1, Q1, Q2, D11) and the solid state switch (K1) are biased on by the current path from ground (i.e., the POWER UP REQUEST input) through the 15 V switch, the solid state switch, and the 14 mA current source (Z2) to the +25 V output of the rectifier and filter. The 15 V switch couples the +15 V output of the 15 V regulator to the airflow sensor. The solid state switch (K1) controls the operation of contactor (K1). The solid state switch (K1) is held energized by the current flow through the series connected resistor and LED. When the solid state switch is energized, the closed contacts of the switch provide a current path through which contactor (K1) is energized. When contactor (K1) is energized, primary power is distributed to the ac line loads.

An AIRFLOW SHUTDOWN or OVERTEMP SHUTDOWN input causes primary power to be removed from the ac line loads connected to the power controller. A ground on either of the inputs shunts the current path which holds the solid state switch (K1) energized. The AIRFLOW SHUTDOWN input is generated by the airflow sensor and causes shutdown of the H7104 power system by energizing the trip coil of the circuit breaker (CB1). The OVERTEMP SHUTDOWN signal lines are common to the three thermostats in the H7104 power system and all thermostats in remote power systems interconnected by the DEC POWER BUS connectors. An OVERTEMP SHUTDOWN input causes shutdown of all interconnected power systems for as long as the OVERTEMP SHUTDOWN signal is present. Additionally, the OVERTEMP SHUTDOWN signal is applied to the battery backup unit via the 3-pin connector on the lower rear portion of the power controller to inhibit operation of the battery backup unit, if installed.

If an overtemperature condition is detected in either the +5 V or +2.5 V power supply assembly, the OVERTEMP signal enables the overtemp detector and relay drive (Q12–Q14, D52, D53), which, in turn drives the OVERTEMP indicator (K1) on the power status indicator of the power controller.

4.3 AC INPUT, RAW DC, AND H7104 BIAS VOLTAGE POWER SUPPLY

The ac input and raw dc sections of the +5 V power supply assembly controls application of the ac input to limit surge currents, converts the ac input to a 300 Vdc potential (± 150 Vdc levels), monitors the 300 Vdc potential, and generates the control signals which enable the H7104 bias voltage power supply and +5 V power supply. The H7104 bias voltage power supply section converts the 300 Vdc potential to bias voltages for use within the H7104 power system.

Figure 4-3 is a functional block diagram of the ac input, raw dc, and H7104 bias voltage power supply sections of the +5 V power supply assembly. The following discussion is keyed to Figure 4-3 and engineering drawings 7016156, 7015856, 5412550 and 5413382.

4.3.1 AC Input and Raw DC Sections

The 115/230 Vac input to the +5 V power supply assembly is routed through the fuse (F1) on the bottom panel assembly to the H7104 bias control power supply.

The 115/230 Vac from the power controller is also routed through a current limiting resistor (R1) on the bottom panel assembly and applied to a rectifier (D1, D2) on the motherboard. The rectifier (D1 and D2) is configured to operate as a voltage doubler when 120 Vac is used as input or as a full wave rectifier when 240 Vac is used as input. The current limiting resistor (R1) on the bottom panel assembly is used to control the rate at which the ± 150 Vdc outputs from the rectifier (D1, D2) reach full potential during initial powerup or after a low line voltage condition has been experienced. When the potential difference between the ± 150 Vdc outputs reaches approximately 200 V, the dc voltage monitor (E1 and E2) asserts a RAW DC signal to the raw dc low driver (Q8, Q9) on the 5 V control board. When the RAW DC signal is asserted, the raw dc low driver deasserts the RAW DC LOW signal, which is used in the fault detect and status display circuits, and asserts a RAW DC LOW signal to the +5 V power supply and to the relay driver (Q11). When the RAW DC LOW signal is asserted, the relay driver (Q11) generates the control signals which energize relay K1 on the bottom panel assembly. With K1 energized, the current limiting resistor R1 is shunted by the closed contacts of K1 and the ac input is applied directly to the rectifier (D1, D2).

If the ac input voltage level drops, and, correspondingly, the ± 150 V outputs of the rectifier (D1, D2) drop below a potential difference of approximately 200 V, the RAW DC output of the dc voltage monitor (E1, E2) is deasserted. Under this condition, the RAW DC LOW signal is asserted to the fault detect and status display circuitry and the RAW DC LOW signal to the +5 V power supply and relay driver (Q11) is deasserted. Deassertion of the RAW DC LOW signal from the relay driver (Q11) inhibits the relay drive signals to relay K1 on the bottom panel assembly. Thus, the current limiting resistor (R1) is re-inserted in the ac input line to reduce the effects of ac input voltage fluctuations on the ± 150 Vdc outputs of the rectifier. Deassertion of the RAW DC LOW signal from the +5 V power supply inhibits the +5 V power supply section of the +5 V power supply assembly during low ac line level conditions.

The ± 150 Vdc outputs of the rectifier (D1, D2) are applied to the H7104 bias voltage power supply and the +5 V power supply sections of the +5 V power supply assembly.

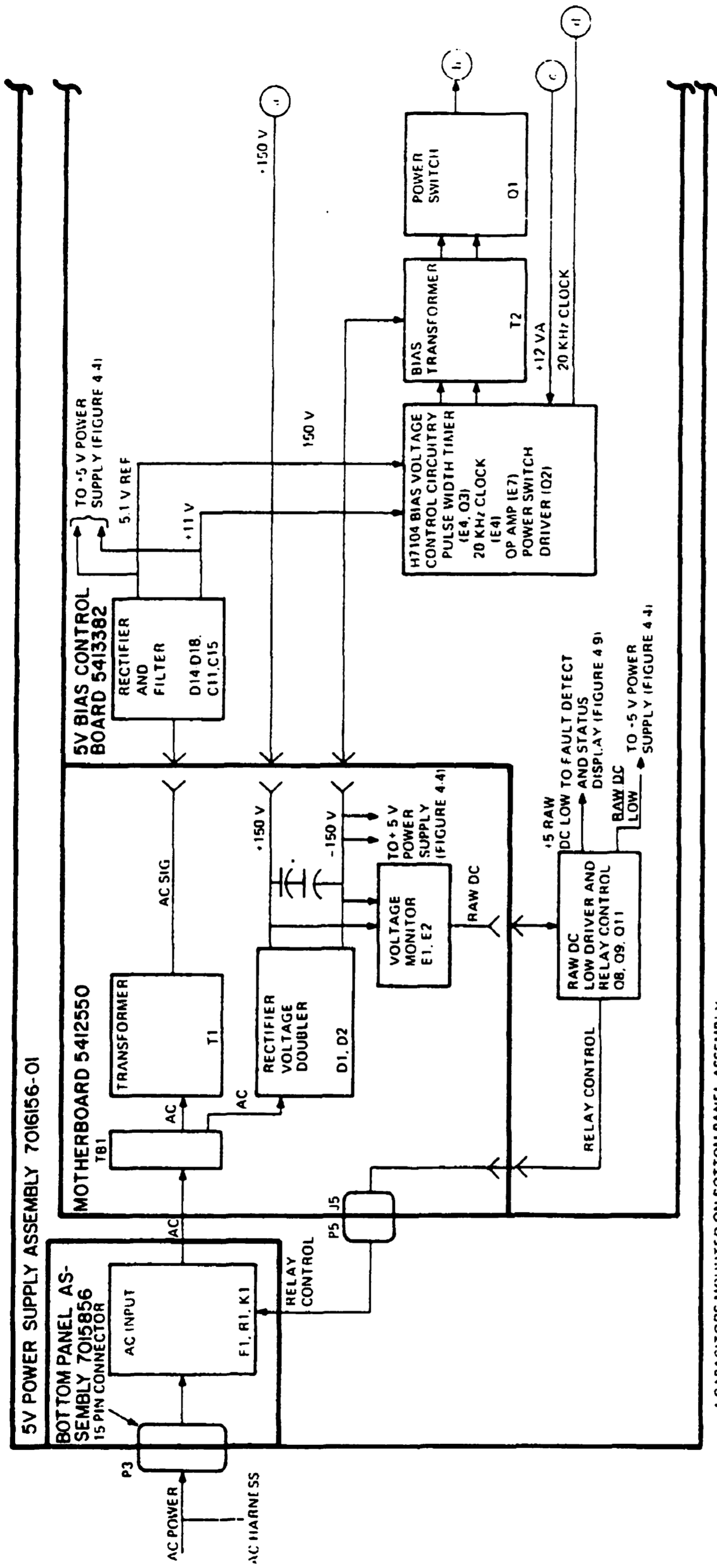

* CAPACITORS MOUNTED ON BOTTOM PANEL ASSEMBLY

Figure 4-3 AC Input, Raw DC, and H7104 Bias Voltage Power Supply Functional Block Diagram (Sheet 1 of 2)

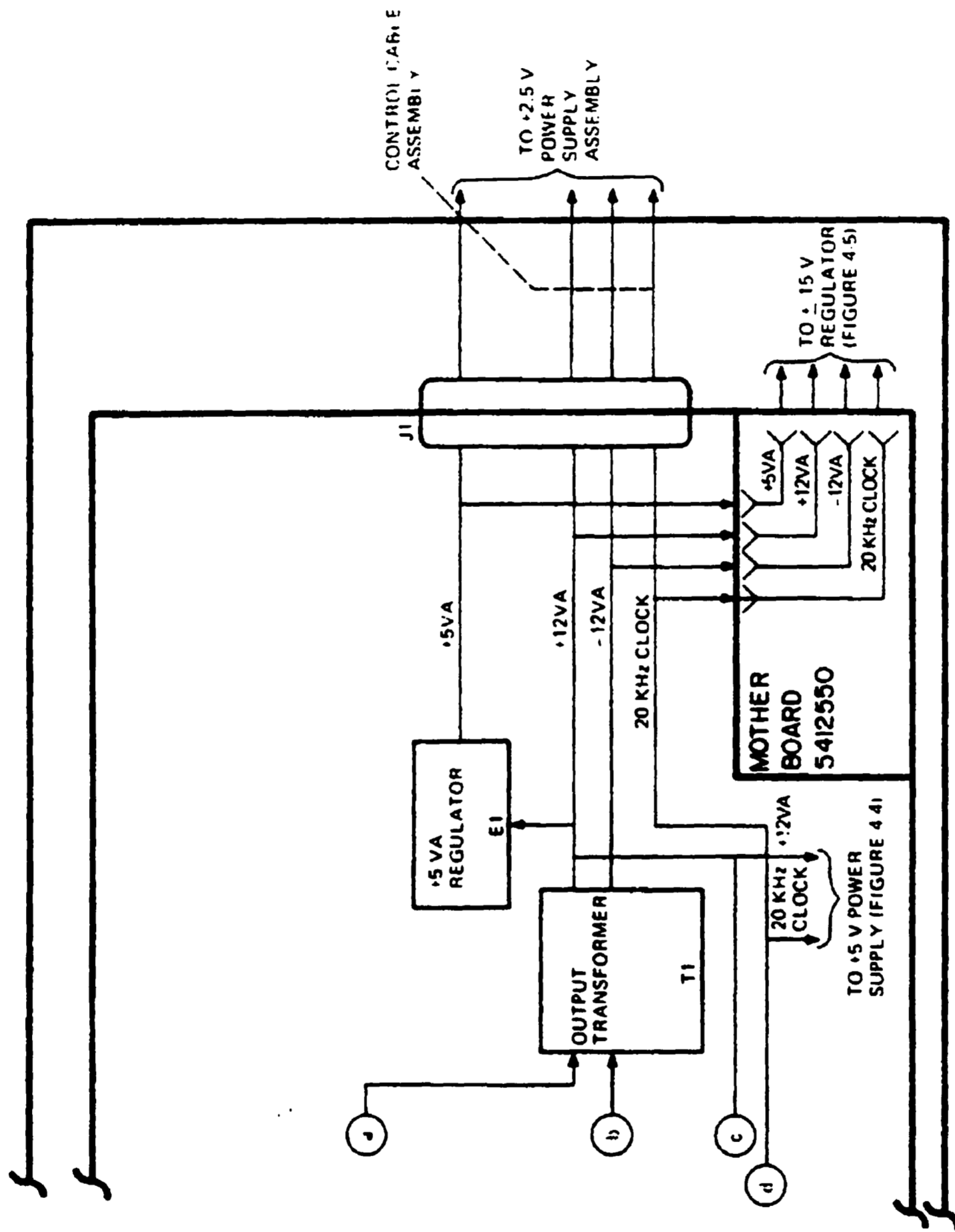

Figure 4-3 AC Input, Raw DC, and H7104 Bias Voltage Power Supply Functional Block Diagram (Sheet 2 of 2)

4.3.2 H7104 Bias Voltage Power Supply

The 115/230 Vac input to the bias control power supply section is asserted to the primary of the ac sense transformer (T1) on the motherboard. The low-level ac signal (AC SIG) from the secondary of T1 is applied to the rectifier (D14–D18) on the 5 V control board, which provides a zener regulated 5.1 Vdc reference voltage output (5.1 V Ref) and an unregulated +11 Vdc output. The 5.1 V Ref and the +11 V outputs provide the bias voltages used within the H7104 bias voltage power supply and the +5 V power supply of the +5 V power supply assembly.

The +12 VA, -12 VA, and +5 VA outputs of the H7104 bias voltage power supply are generated from the ± 150 V inputs from the rectifier (D1, D2).

NOTE

The A designation of the +12 VA, -12 VA, and +5 VA outputs denotes that these voltages are bias voltages used within the H7104 power system.

The ± 150 V inputs are applied to the flyback transformer (T1) and power switch (Q1) on the 5 V control board. The power switch controls gating of a 300 Vdc potential (coupling of the ± 150 Vdc inputs) through the primary of T1 to effect regulation of the +12 VA output from the secondary of T1. The -12 VA output is not regulated, but closely follows the +12 VA output. The +5 VA output is generated from the +12 VA output.

Regulation of the +12 VA output of the H7104 bias voltage power supply is effected by varying the duty cycle of the power switch using an operational amplifier (op amp, E7), pulse width timer (E4, Q3), 20 kHz clock (E4), and power switch driver (Q2). The basic frequency at which the ± 150 V inputs are gated through T1 is established by the 20 kHz clock (E4). The 20 kHz clock is an astable multivibrator which generates a 20 kHz pulse output when the +11 V signal is asserted.

The 20 kHz pulse output of the clock in conjunction with the power switch driver (Q2) limits the duty cycle of the power switch (Q1) to a maximum of approximately 22 percent. The op amp (E7) and pulse width timer (E4, Q3) determine the actual duty cycle of the power switch (Q1) based on the condition of the +12 VA output. Duty cycle regulation and thus regulation of the +12 VA output is described in the following paragraphs.

When the 20 kHz clock output goes high, the low-to-high transition resets the pulse width timer (E4, Q3) output to a high. The time that the output of the pulse width timer remains high is dependent upon the error voltage sensed at the +12 VA bias input of the op amp (E7) relative to the +5.1 V Ref input. The output of the op amp controls the rate at which C16 charges to the threshold level required to set the output of the pulse width timer to a low. The timing relationship between the 20 kHz clock and pulse width timer outputs (relative to the charge on C16) is illustrated as follows.

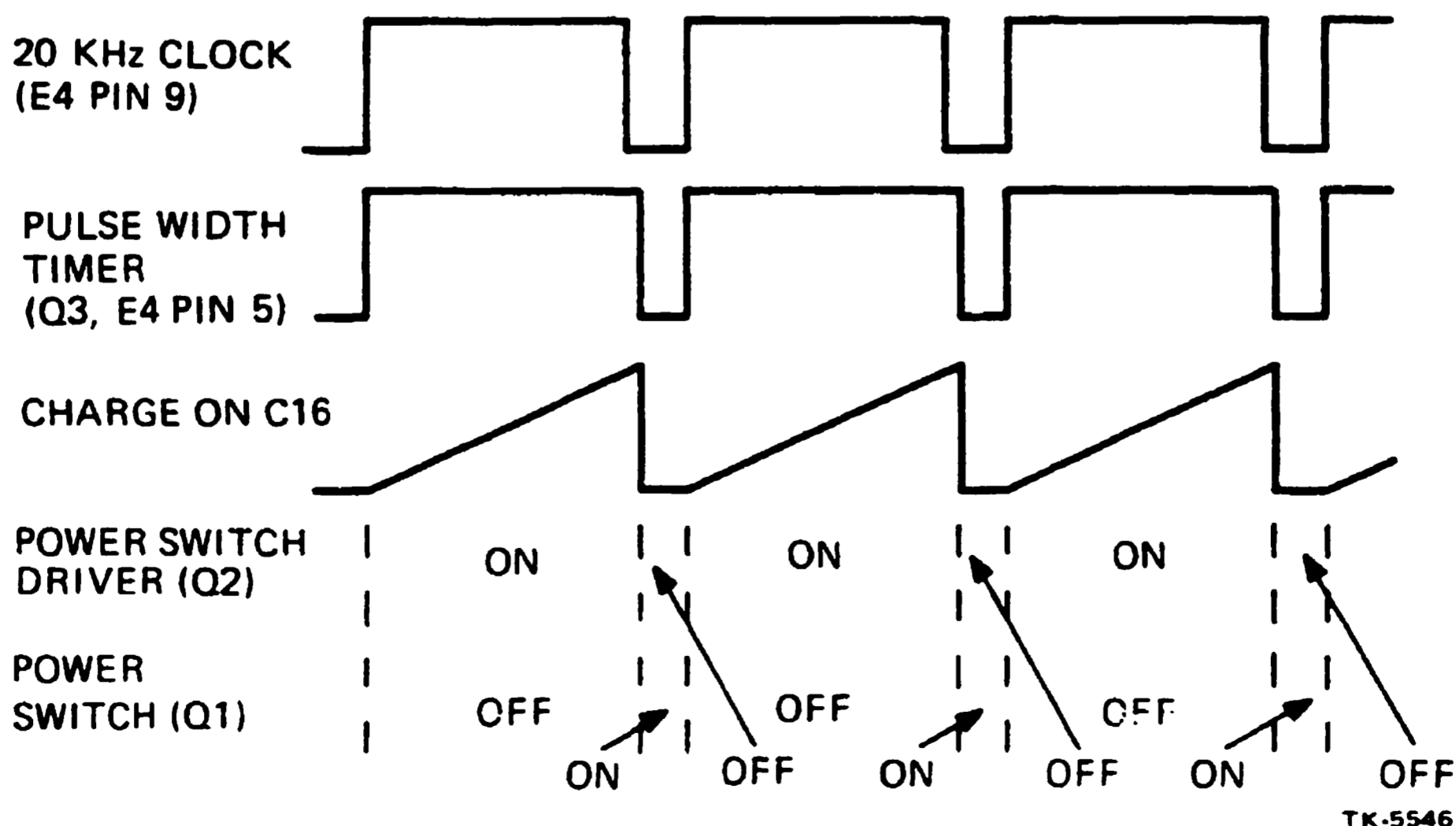

Diodes (D19 and D20) in the outputs of the 20 kHz clock and the pulse width timer form an OR gate which controls the power switch driver (Q2). When either the 20 kHz clock or pulse width timer output is high, the power switch driver is biased on and the charge developed across C9 during the power switch driver off time is bled off through the primary of transformer (T2). The induced voltages in the secondary of T2 bias the power switch (Q1) off. When C16, at the threshold input of the pulse width timer (E4, Q3), has charged to the threshold level, the pulse width timer output is set to a low causing the power switch driver (Q2) to turn off. When the power switch driver is turned off, the induced polarity change coupled across T2 causes the power switch to turn on, coupling the 300 Vdc potential (± 150 Vdc) through the primary of T1. While the power switch is on, diodes D5 and D7 in the secondary are reverse biased and the charge stored on the output capacitors (C5–C8) discharge the stored energy into the load. When the power switch is turned off, the polarity in the secondary of the flyback transformer changes and the induced voltages forward bias diodes D5 and D7 which allows the induced voltages to discharge into the output capacitors and loads.

If an overload condition occurs in the +12 VA output, diode D8, connected between the +12 VA leg of the flyback transformer and the power switch driver, will become forward biased and will hold the power switch driver on. Holding the power switch driver (Q2) on will inhibit the power switch (Q1) and consequently will inhibit the +12 VA, -12 VA, and +5 VA outputs.

The +5 VA bias voltage output of the H7104 bias voltage power supply is provided by an LM340T-5 three-terminal regulator. The regulator uses the +12 VA output to generate the +5 VA output.

4.4 +5 V POWER SUPPLY

The +5 V power supply of the +5 V power supply assembly generates and regulates the +5 Vdc, 10 to 135 A, output. The +5 V power supply also generates the ± 30 Vdc levels used by the ± 15 Vdc regulator. Figure 4-4 is a functional block diagram of the +5 V power supply. The following description is keyed to Figure 4-4 and engineering drawings 7016156, 7016151, 5413382, and 5412550.

The +5 V, +30 V, and -30 V outputs of the +5 V power supply are generated from the ± 150 Vdc inputs from the ac input, raw dc, and H7104 bias voltage power supply. The ± 150 Vdc inputs are gated through the primary of transformer (T1) on the output panel assembly via the power switch (Q1–Q4) on the motherboard to effect regulation of the +5 V, 10 to 135 A output. The ± 30 Vdc outputs to the ± 15 V regulator are unregulated.

4.4.1 Regulation of +5 V, 10 to 135 A Output

Regulation of the +5 V output is effected by varying the duty cycle of the power switch (Q1–Q4). The basic frequency at which the ± 150 V inputs are gated through T1 is established by the 20 kHz clock (E9). The 20 kHz clock is an astable multivibrator which generates a 20 kHz pulse. The 20 kHz clock of the +5 V power supply is synchronized with the 20 kHz clock of the H7104 bias voltage power supply.

The 20 kHz pulse output of the clock (E9) in conjunction with the output of the pulse width timer (Q5, E9) limits the duty cycle of the power switch (Q1–Q4) to a maximum of 46 percent. The actual duty cycle of the power switch (Q1–Q4) varies with output voltage fluctuations due to changing load conditions and variations in the ac line level. (The nominal duty cycle of the power switch is approximately 30 percent; i.e., 15 μ s on and 35 μ s off.)

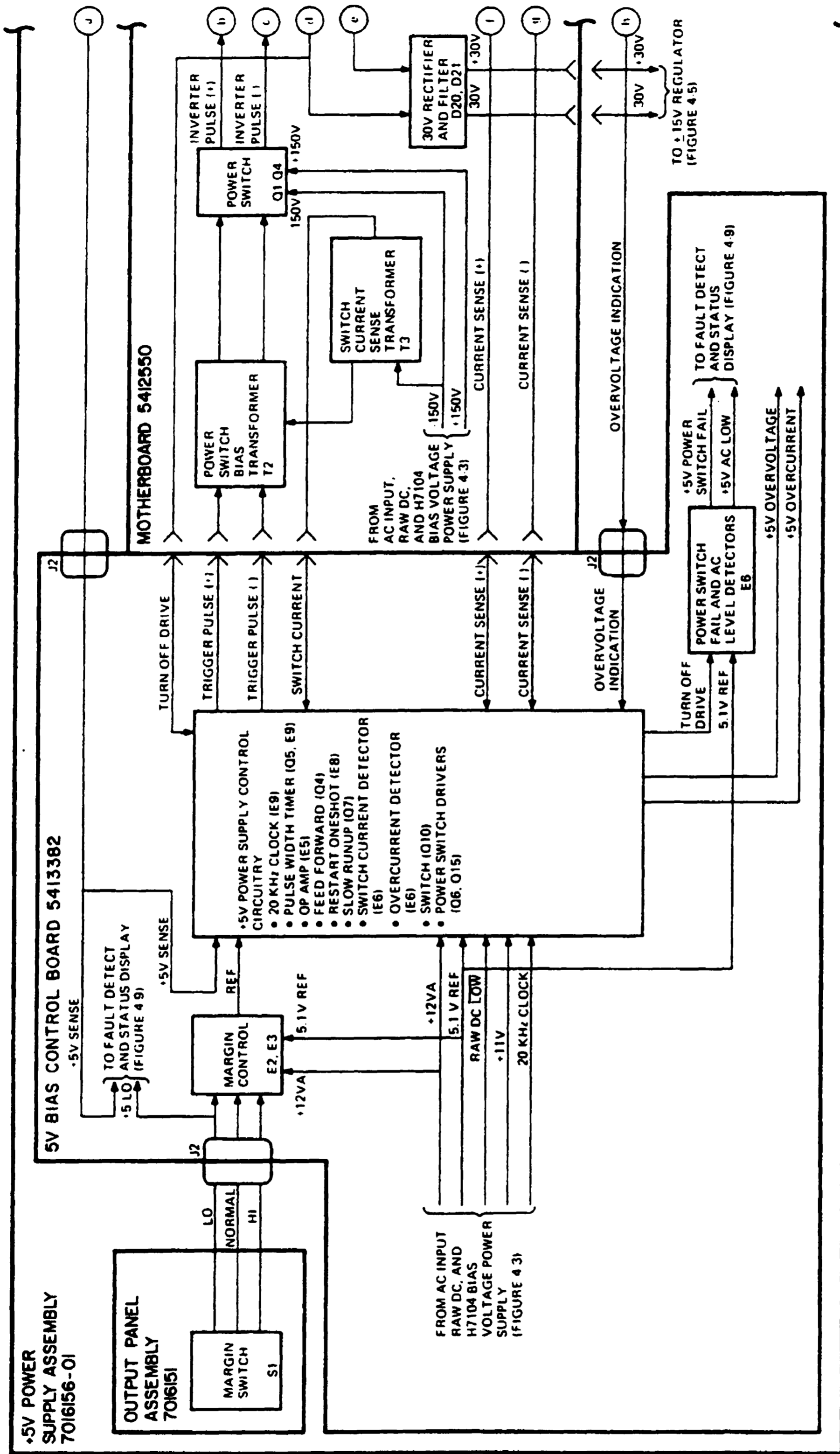

14-55519

Figure 4-4 +5 V Power Supply Functional Block Diagram (Sheet 1 of 2)

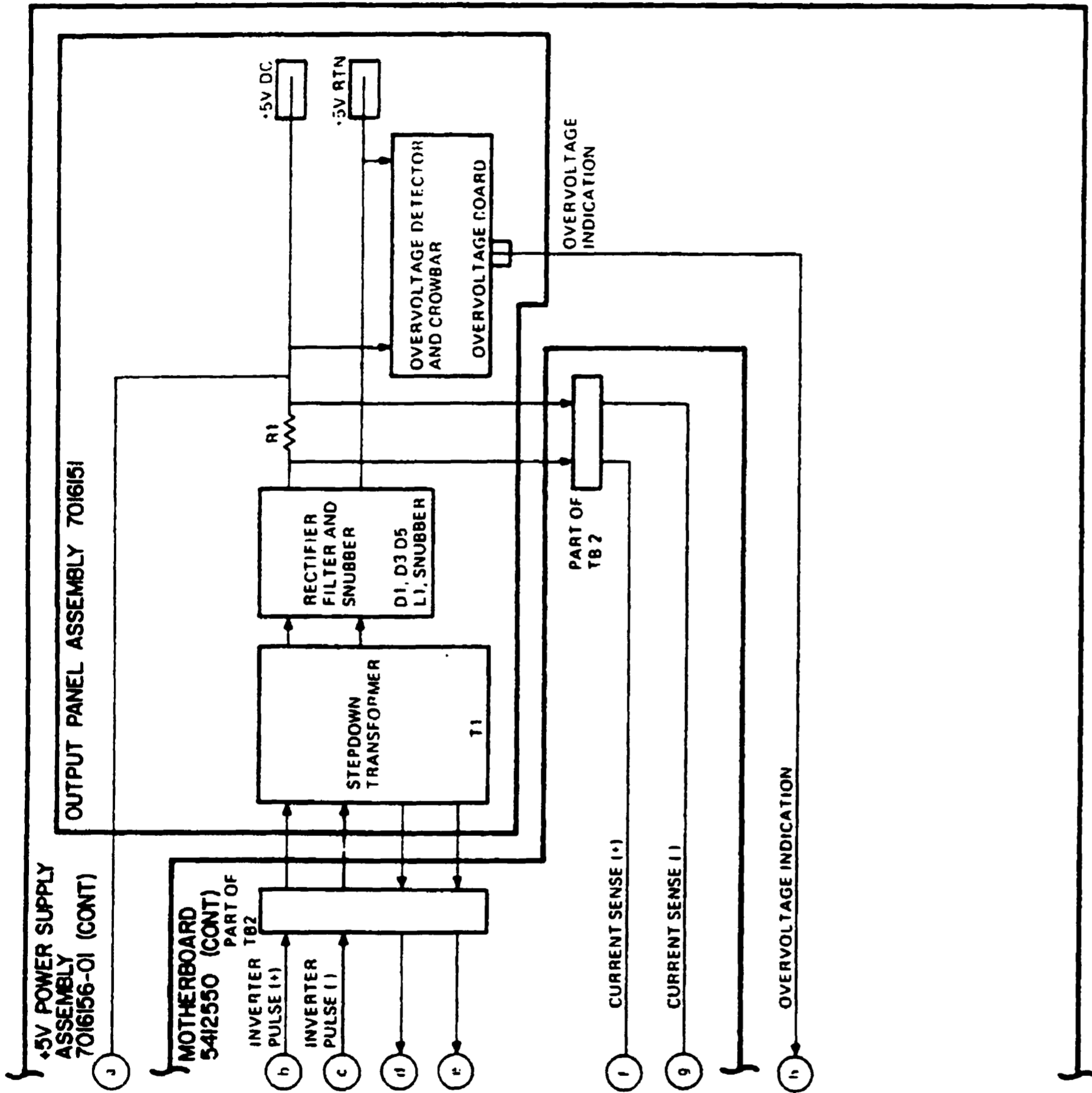

1 X 10/40

Figure 4-4 +5 V Power Supply Functional Block Diagram
(Sheet 2 of 2)

When the 20 kHz clock output goes high, the low-to-high transition resets the pulse width timer (Q5, E9) output to a high. The time that the output of the pulse width timer remains high is dependent upon the error voltage (i.e., the voltage difference between the +5 V sense and REF voltage inputs) detected at op amp (E5) and the peak voltage (turnoff drive) input to the feed forward (Q4). Op amp (E5) senses the variations in the output voltage due to changing load conditions and changes the control voltage level to which C25 at the threshold input must charge to set the pulse width timer output to a low. The rate at which C25 charges is controlled by the feed forward (Q4). Changes in the ac line level (determined by sensing the peak voltage, TURN OFF DRIVE, coupled through the transformer (T1)) control the operation of the feed forward (Q4). Q4 translates the peak voltage stored across C22 at the input of Q4 to a current flow rate which is inversely proportional to peak voltage. Thus, as peak voltage drops, the rate at which C25 charges increases. Changing the charge rate of C25 and/or the control voltage level to which C25 must charge effects the time required to set the output from the pulse width timer (Q5, E9) to a low. When the charge on C25 reaches the control voltage level, the timer is set and the charge on C25 is bled off.

Diodes (D26 and D27) at the outputs of the 20 kHz clock and the pulse width timer form part of an OR gate which controls the power switch drivers (Q6, Q15). When either the 20 kHz clock or pulse width timer output is high, the power switch drivers are biased on and the charge, which was developed across C32 during the power switch drivers' off time, is bled off (TRIGGER PULSE) through the primary of transformer (T2). The induced voltages in the secondary of T2 bias the power switch (Q1-Q4) off. When both the 20 kHz clock and pulse width timer outputs are low, the power switch drivers (Q6, Q15) are turned off. When the power switch drivers are turned off, the induced polarity change coupled across T2 biases the power switch (Q1-Q4) on. The ± 150 Vdc inputs to the the power switch are coupled through the power switch providing a 300 Vdc INVERTER PULSE through the primary of transformer (T1). Transformer (T1) provides a low voltage, high current output at the two secondary windings, which is rectified and filtered to produce the +5 V, 10 to 135 A output. The power switch (Q1-Q4) remains on until the output of the 20 kHz clock and/or the pulse width timer goes high. The following timing diagram illustrates the timing relationship between the output of the 20 kHz clock and the pulse width timer (relative to the charge on C25), and the operation of the power switch drivers (Q6, Q15) and the power switch (Q1-Q4).

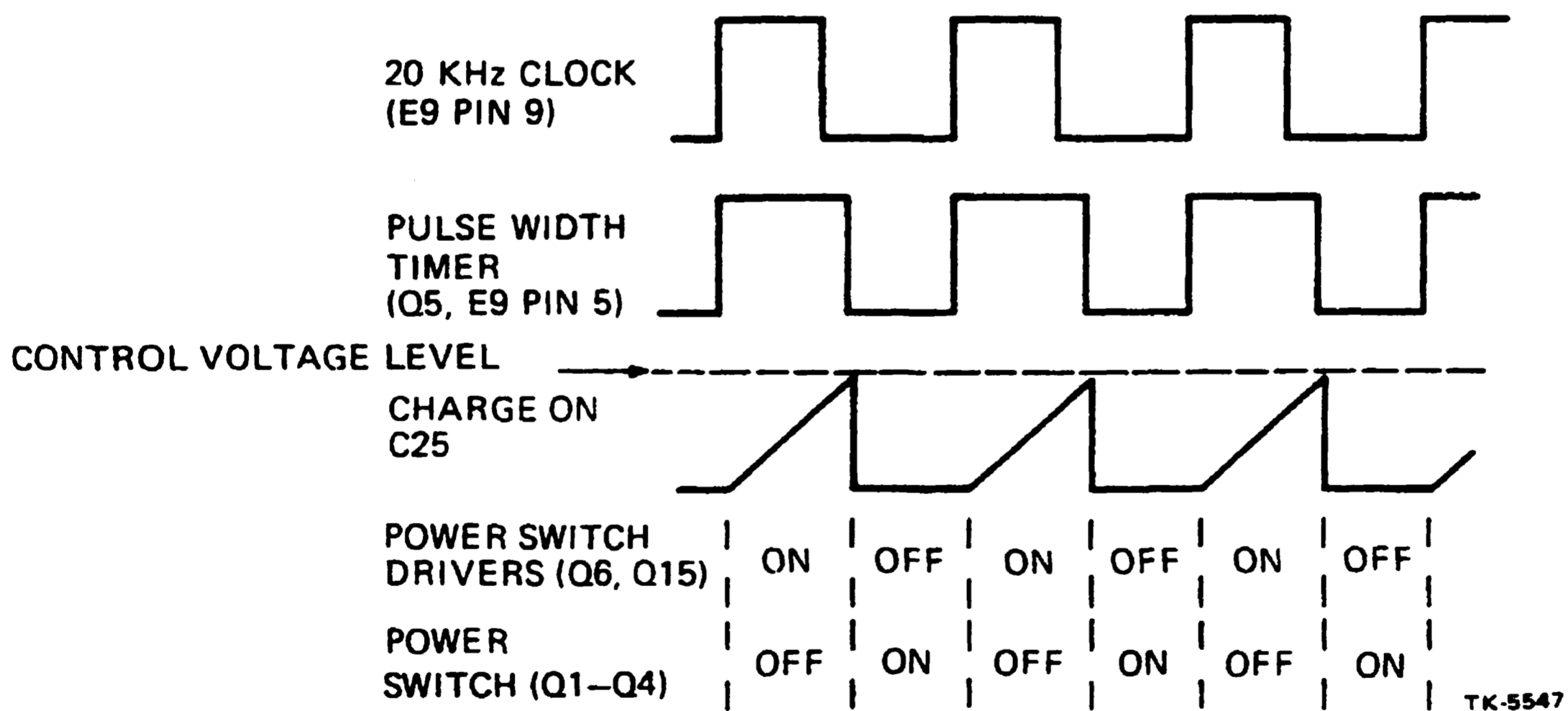

The output voltage of the +5 V power supply may be increased or decreased by 5 percent by way of the HI/NORMAL/LO switch (S1) on the output panel assembly. S1 and the margin control circuitry (E2, E3) on the 5 V control board reduce or increase the REF voltage input to op amp (E5). Changing the REF voltage input to E5 results in a change to the control voltage input of the pulse width timer, which increases or decreases duty cycle to provide the selected change in output voltage level. If the LO level condition is selected, a +5 LO signal is applied to the fault detect and status display circuitry to prevent the low level +5 V output from initiating system shut down (i.e., inhibits generation of AC LO and DC LO resulting from the low level +5 V SENSE input).

The ± 150 Vdc levels coupled through the power switch (Q1–Q4) provide INVERTER pulses of known current. The current flow through the power switch is sensed in transformer (T3). If a power switch failure causes pulses of higher current, the switch current detector (E6) resets the output of the pulse width timer to a high prior to the low-to-high transition output of the 20 kHz clock which normally resets the pulse width timer. This reduces the duty cycle of the power switch (Q1–Q4) and results in a decrease in voltage and power of the +5 V, 10 to 135 A output.

4.4.2 +5 V Overvoltage Protection

Overvoltage protection for the +5 V power supply is provided by the overvoltage detector and crowbar circuit on the output panel assembly. If an overvoltage condition occurs, the output of the power supply is shunted to ground and the operation of the power supply is inhibited for approximately 1 second. Then, the power supply is re-activated.

If the overvoltage threshold (approximately 6.8 V) is exceeded, an OVERVOLTAGE INDICATION is generated and the crowbar circuit is energized. The crowbar, when energized, immediately pulls the +5 V output level to approximately 0.7 V. When the current flow through the crowbar necessary to fully discharge capacitors C3 and C4 ceases, the crowbar is reset, allowing the +5 V output to be re-established. The OVERVOLTAGE INDICATION generated when the crowbar is energized is terminated when the crowbar is reset. The OVERVOLTAGE INDICATION triggers the restart one shot (E8) on the 5 V control board. The OVERVOLTAGE INDICATION is applied also to the fault detect and status display circuitry.

When triggered, the restart one shot (E8) inhibits the power switch driver (Q6, Q15) via diode (D36) and holds the slow run-up (Q7) on for a period of approximately 1 second. With Q7 on, the charge on C38 is bled off to ground, which clamps the REF input to op amp (E5) at a ground level. When Q7 is turned off, C38 is gradually charged until it reaches the level of the REF voltage; a period of approximately 100 ms. Gradually increasing the level of the REF voltage results in a gradually increasing duty cycle of the power switch and gradual run-up of the +5 V output.

4.4.3 +5 V Overcurrent Protection

Overcurrent protection for the +5 V power supply is provided by sensing the current flow through the current sense resistor (R1) on the output panel assembly. The \pm CURRENT SENSE signals are detected in the overcurrent detector (E6) on the 5 V control board. If an overcurrent condition ($155 \text{ A} \pm 10\%$) occurs, the overcurrent detector (E6) triggers the restart one shot (E8). E8 effects power supply shutdown for a period of approximately one second and re-activates the power supply after the one second period as discussed in the preceding paragraph.

4.4.4 Low Level AC Input Protection

The operation of the +5 V power supply is inhibited during low ac line level conditions. The RAW DC LOW input from the ac input, raw dc, and H7104 bias voltage power supply is a low-level signal whenever the potential difference between the ± 150 Vdc levels is less than approximately 200 V. The low RAW DC LOW input enables switch (Q10), which turns on Q7 to effect slow run-up when the RAW DC LOW signal is terminated. Switch Q10 also inhibits the power switch drivers (Q6, Q15) via diode (D42) as long as the low RAW DC LOW signal is applied.

4.4.5 +5 V Monitor Circuits

Monitor circuits (power switch detector, E6, and ac level detector, E6) peak sample the TURN OFF DRIVE signal. The peak voltage of the TURN OFF DRIVE signal is stored in capacitor (C31). If the stored level drops below approximately 68 V, the ac level detector generates a +5 V AC LOW signal. If the stored level drops below approximately 35 V, the power switch detector (E6) generates a +5 V POWER SWITCH FAIL signal. The +5 V POWER SWITCH FAIL and +5 V AC LOW outputs are applied to the fault detect and status display circuits.

4.5 15 V REGULATORS

The ± 15 V regulators of the +5 V power supply assembly converts the unregulated ± 30 Vdc inputs from the +5 V power supply to regulated +15 V, 0.2 to 2 A and -15 V, 0.35 to 3.5 A outputs. Figure 4-5 is a functional block diagram of the ± 15 V regulators. The following description is keyed to Figure 4-5 and to engineering drawings 7016156, 5413417, and 7016151.

The ± 15 V regulators are switching regulators which control output voltage and current by varying the duty cycle of the power switch relative to sampled output voltage levels. The ± 15 Vdc regulators control gating of the ± 30 Vdc inputs through the power switches. When the power switches are turned on, current flow is enabled through coil (L1) to charge capacitors C13 and C16. When the power switches are turned off, current flow through L1 is maintained by flyback diode (D6) and discharge of capacitors (C13 and C16).

Regulation of the ± 15 V outputs is effected by varying the duty cycle of the power switches (Q1 and Q4). The basic frequency at which the ± 30 Vdc inputs are gated through the power switches is established by the 20 kHz clock (E5). E5 is an astable multivibrator which produces a 20 kHz pulse output. The 20 kHz clock of the ± 15 V regulators is synchronized with the 20 kHz clock of the H7104 bias voltage power supply.

4.5.1 Regulation of +15 V, 0.2 to 2 A Output

Regulation of the +15 Vdc 0.2 to 2 A output is effected by varying the duty cycle of power switch (Q1). The 20 kHz pulse output of the clock (E5) in conjunction with the output of the pulse width timer (E5) limits the duty cycle of the power switch (Q1) to a maximum of approximately 82 percent. The actual duty cycle of power switch (Q1) varies with output voltage fluctuations due to changing load conditions. (The nominal duty cycle of the power switch is approximately 70 percent; 35 μ s on and 15 μ s off.)

When the 20 kHz clock output (Y1) goes low, the high to low transition resets the pulse width timer (E5) output (Y2) to a high. The time that the output of the pulse width timer remains high is dependent upon the error voltage (i.e., the voltage difference between the VOLTAGE SENSE and REF inputs) detected at op amp (E3). Op amp (E3) senses the variations in the output voltage due to changing load conditions and changes the control voltage level to which C5 at the threshold input must charge to set the pulse width timer output to a low. The rate at which C5 charges is fixed by R10 and C5. Changing the control voltage level to which C5 must charge, effects the time required to set the output from the pulse width timer (E5) to a low. When the charge on C5 reaches the control voltage level, the timer is set and the charge on C5 is bled off.

Diode (D3) at the outputs of the 20 kHz clock and the pulse width timer form part of an AND gate which controls the power switch driver (Q2). When both the 20 kHz clock and pulse width timer outputs are high, the power switch driver is biased on. The power switch driver (Q2) provides the bias voltage to turn on the +15 V power switch (Q1). The power switch (Q1) remains on until the output of the pulse width timer is set to a low. The following timing diagram illustrates the timing relationship between the output of the 20 kHz clock and the pulse width timer (relative to the control voltage level and charge on C5), and the operation of the power switch driver (Q2) and the power switch (Q1).

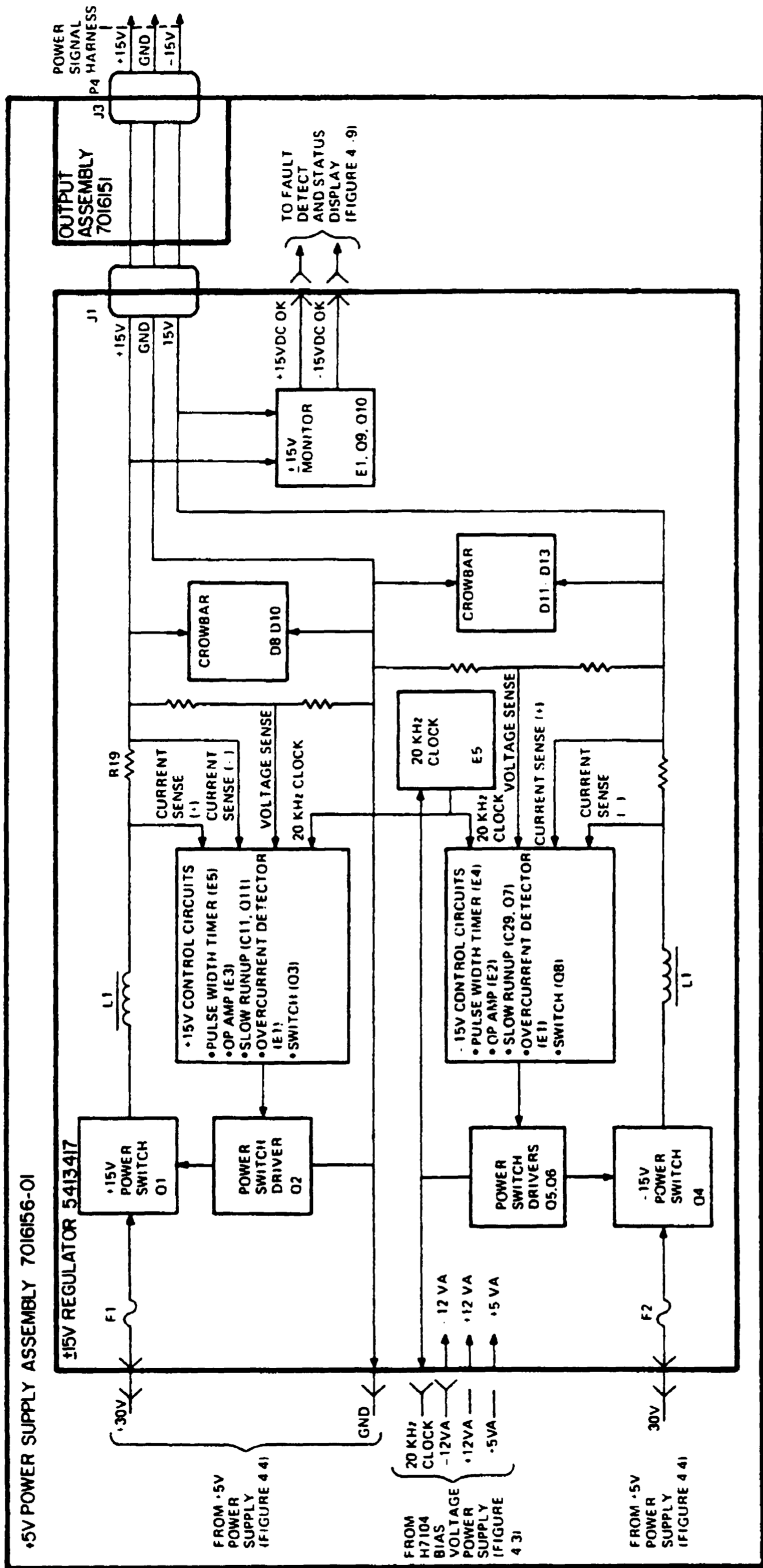
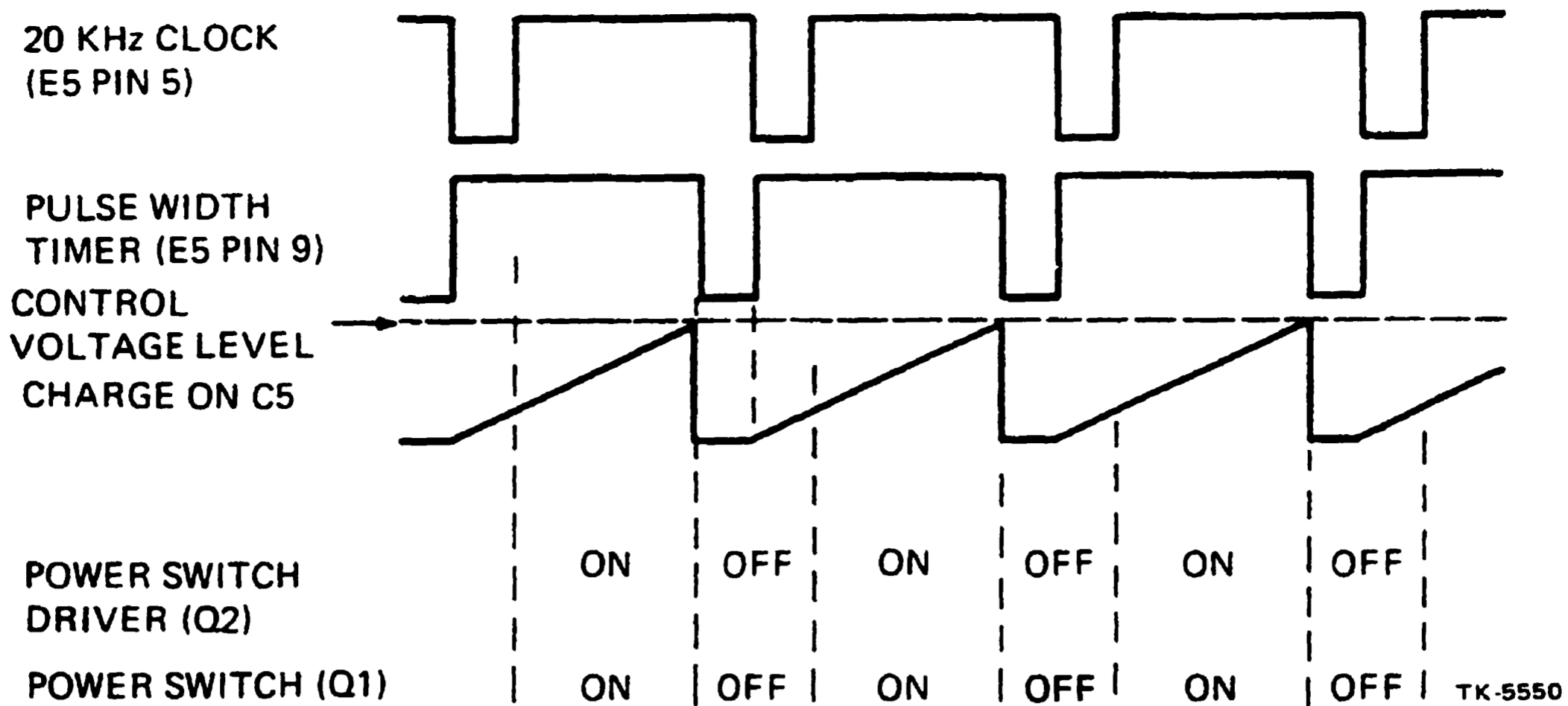

Figure 4-5 ±15 V Regulators Functional Block Diagram



4.5.2 Regulation of -15 V, 0.35 to 3.5 A Output

Regulation of the -15 Vdc, 0.35 to 3.5 A output is effected by varying the duty cycle of the power switch (Q4). The 20 kHz pulse output (Y1) of the clock (E5) in conjunction with the output of the pulse width timer (E4) limits the duty cycle of the power switch (Q4) to a maximum of approximately 82 percent. The actual duty cycle of the power switch (Q4) varies with output voltage fluctuations due to changing load conditions. (The nominal duty cycle of the power switch is approximately 70 percent; 35 μ s on and 15 μ s off.)

When the 20 kHz clock output goes low, the high to low transition resets the pulse width timer (E4) output to a high. The time that the output of the pulse width timer remains high is dependent upon the error voltage (i.e., the voltage difference between the VOLTAGE SENSE and REF inputs) detected at op amp (E2). Op amp (E2) senses the variations in the output voltage due to changing load conditions and changes the rate at which C20 charges. As the output voltage potential drops, the rate at which C20 charges decreases. Changing the charge rate of C20 effects the time required to set the output from the pulse width timer (E4) to a low. When the charge on C20 reaches approximately 6.8 V, the timer is set and the charge on C20 is bled off.

Diode (D14) at the outputs of the 20 kHz clock and the pulse width timer form part of an AND gate which controls the power switch drivers (Q5, Q6). When both the 20 kHz clock and pulse width timer outputs are high, the power switch drivers are biased on. The power switch drivers (Q5, Q6) provide the bias voltage to turn on the -15 V power switch (Q4). The power switch (Q4) remains on until the output of the pulse width timer is set to a low. The following timing diagram illustrates the timing relationship between the output of the 20 kHz clock and the pulse width timer (relative to the charge on C20), and the operation of the power switch drivers (Q5, Q6) and the -15 V power switch (Q4).

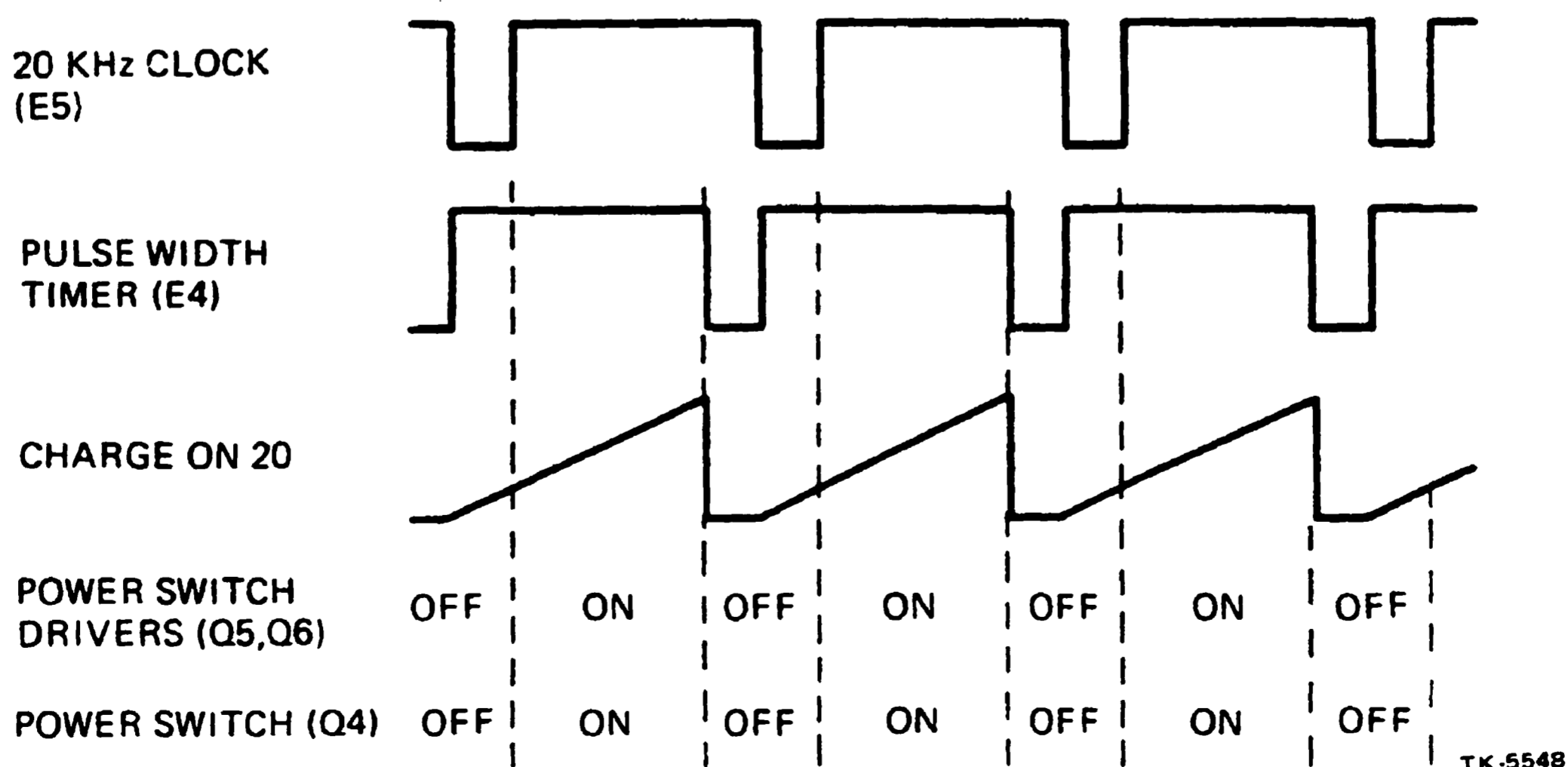

4.5.3 15 V Regulators Overcurrent Protection

The current flow through the ± 15 V regulators is sensed across resistors (R19 and R37). If the current flow exceeds preset limits (i.e., 2.4 A $\pm 10\%$ in the +15 V regulator and 4.2 A $\pm 10\%$ in the -15 V regulator), the applicable overcurrent detector (E1) is turned on. The overcurrent detectors turn on the inhibit drivers which reset the applicable pulse width timer to a low and inhibits the power switch drivers. This reduces the duty cycle of the ± 15 V power switches and results in a decrease in output voltage levels and power. The overcurrent detectors also trigger the applicable slow run-up circuit. When the slow run-up is triggered, the REF voltage output to the applicable op amp is clamped at a ground level. When the overcurrent condition ends, the output of the applicable overcurrent detector returns to a high which turns off the inhibit drivers and enables the slow run-up. When the slow run-up circuit is enabled, the REF voltage output is gradually increased to peak reference level over a period of approximately 200 ms. Gradually increasing the level of the REF voltage results in a gradually increasing duty cycle and gradual run-up of the regulator output.

4.5.4 15 V Regulators Overvoltage Protection

Overvoltage protection for the ± 15 V regulators is provided by the crowbar circuits (D8-D10 and D11-D13). Should an overvoltage condition occur (output potential exceeds approximately 18 V) the applicable crowbar will be enabled and the output will be clamped at approximately 0.7 V. The crowbar circuits may be reset by removing and re-applying power to the H7104 power system.

4.5.5 15 V Regulators Monitor Circuits

Monitor circuits (E1) sample the ± 15 V outputs and provide status signal outputs (+15 V DC OK and -15 V DC OK) to the fault detect and status display circuits. The monitor circuits enable the applicable driver (Q9 or Q10) if the ± 15 V regulators output is out of tolerance (i.e., the output potential drops below approximately 14.25 V).

4.6 AC INPUT, RAW DC, AND +2.5 V POWER SUPPLY

The ac input and raw dc sections of the +2.5 V power supply assembly controls application of the ac input to limit surge currents, converts the ac facility power input to a 300 Vdc potential (± 150 Vdc levels), monitors the 300 Vdc potential, and generates control signals which control the ac input sections and enable the +2.5 V power supply. The +2.5 V power supply section uses the 300 Vdc potential to generate a regulated +2.5 Vdc, 8.5 to 85 A output and unregulated ± 30 V outputs.

Figure 4-6 is a functional block diagram of the ac input, raw dc, and +2.5 V power supply sections of the +2.5 V power supply assembly. The following description is keyed to Figure 4-6 and engineering drawings 7016157, 7015856, 7015857, 5413396, and 5412550.

4.6.1 AC Input and Raw DC Sections

The 120/240 Vac from the power controller is routed through a current limiting resistor (R1) on the bottom panel assembly and applied to a rectifier (D1, D2) on the motherboard. The rectifier (D1, D2) is configured to operate as a voltage doubler when 120 Vac is used as input or as a full wave rectifier when 240 Vac is used as input. The current limiting resistor (R1) on the bottom panel assembly is used to control the rate at which the ± 150 Vdc outputs from the rectifier (D1, D2) reach full potential during initial power up or after a low line voltage condition has been experienced. When the potential difference between the ± 150 Vdc outputs reaches approximately 200 V, the dc voltage monitor (E1, E2) asserts a RAW DC signal to the relay control (Q3, Q5, Q6, Q15) on the 2.5 V control board. When the RAW DC signal is asserted, the relay control generates a RELAY DRIVE output, a low RAW DC OK output and opens the RELAY DRIVE OK output. The RELAY DRIVE output energizes relay (K1) on the bottom panel assembly. With K1 energized, the current limiting resistor (R1) is shunted by the closed contacts of K1 and the ac input is applied directly to the rectifier (D1, D2). The low RAW DC OK and open RELAY DRIVE OK outputs enable the +2.5 V power supply.

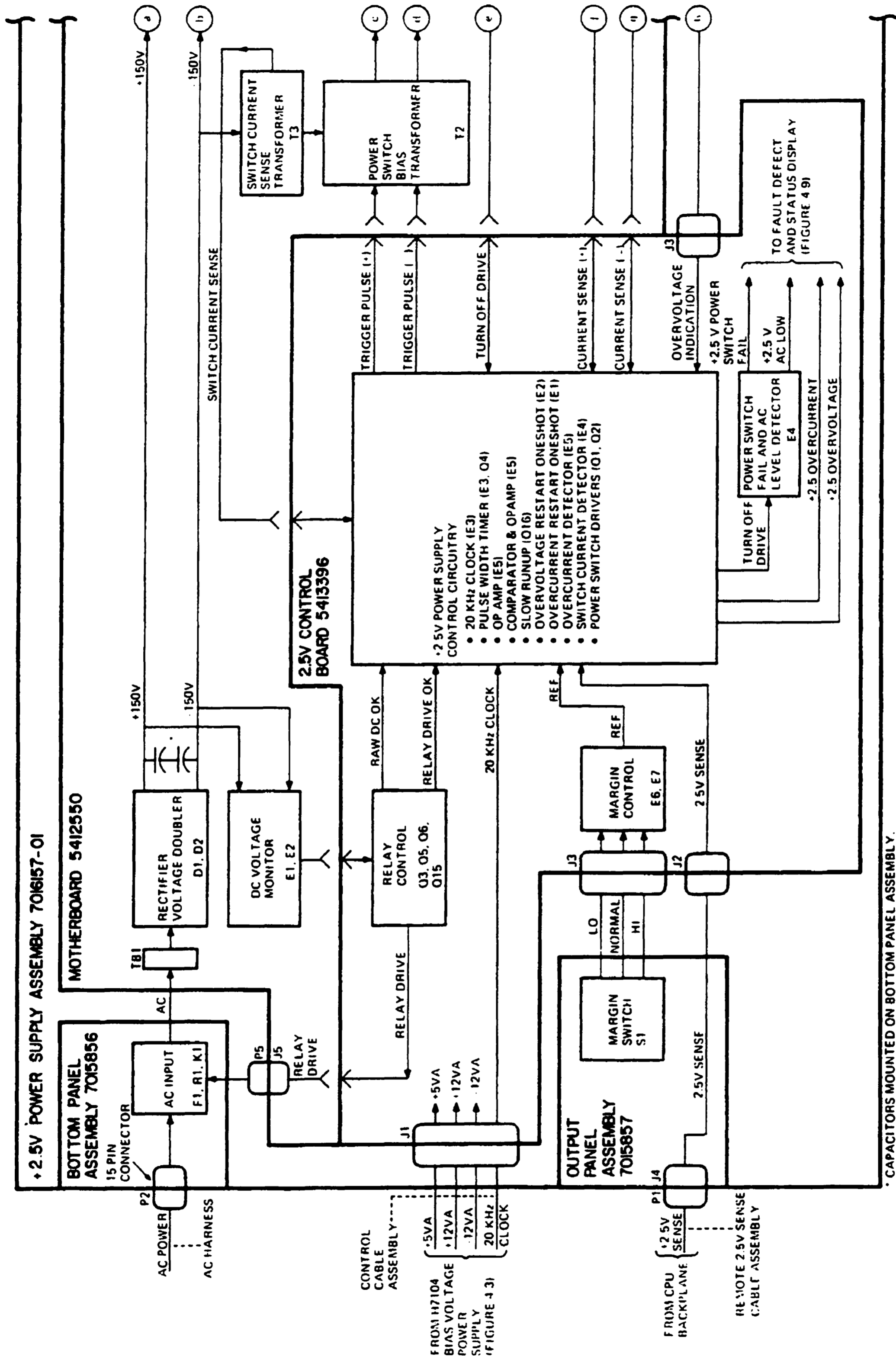

Figure 4-6 AC Input, Raw DC, and +2.5 V Power Supply Functional Block Diagram (Sheet 1 of 2)

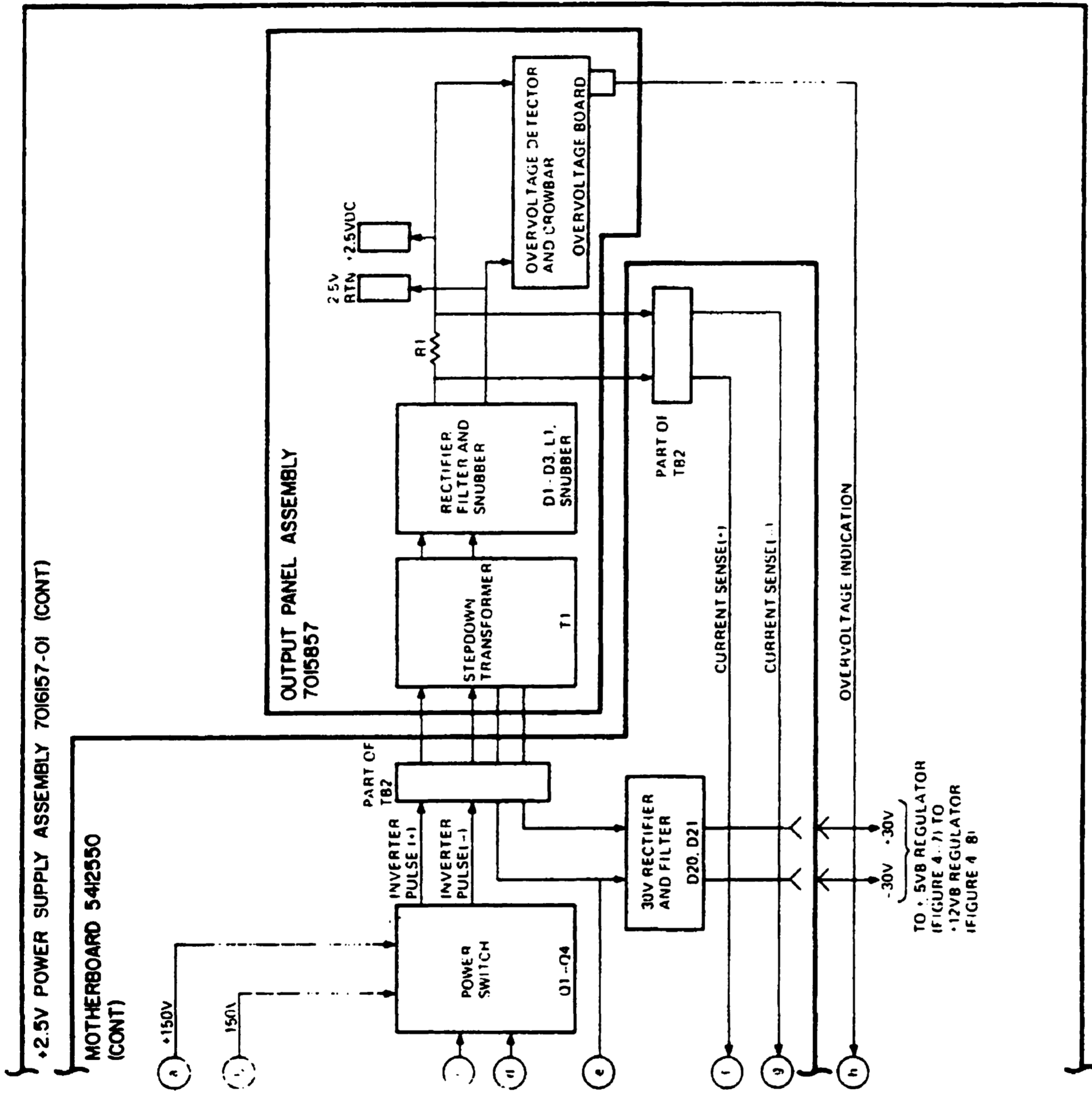

Figure 4-6 AC Input, Raw DC, and +2.5 V Power Supply Functional Block Diagram (Sheet 2 of 2)

If the ac input voltage level should drop and correspondingly the ± 150 V outputs of the rectifier (D1, D2) drop below a potential difference of approximately 200 V, the RAW DC output of the dc voltage monitor (E1, E2) is deasserted. Under this condition, the RAW DC OK and RELAY DRIVE OK outputs of the relay control are set to a high and the RELAY DRIVE output is deasserted. Deassertion of the RELAY DRIVE output causes relay (K1) on the bottom panel assembly to de-energize. Thus, the current limiting resistor (R1) is re-inserted in the ac input line to reduce the effects of ac input voltage fluctuations on the ± 150 Vdc outputs of the rectifier. The high RAW DC OK and RELAY DRIVE OK signals inhibit the +2.5 V power supply section of the +2.5 V power supply assembly during low ac line level conditions.

4.6.2 +2.5 V Power Supply

The +2.5 V power supply section of the +2.5 V power supply assembly generates and regulates the +2.5 Vdc, 8.5 to 85 A output. The +2.5 V power supply also generates the ± 30 Vdc levels used by the ± 5 VB and +12 VB dc regulators. The +2.5 V, +30 V, and -30 V outputs of the +2.5 V power supply are generated by gating ± 150 Vdc through the primary of flyback transformer (T1) on the output panel assembly. The power switch (Q1-Q4) on the motherboard controls gating of the ± 150 V inputs through the primary of T1 to effect regulation of the +2.5 Vdc, 8.5 to 85 A output. The ± 30 Vdc outputs are unregulated.

4.6.2.1 Regulation of +2.5 V, 8.5 to 85 A Output – Regulation of the +2.5 V output is effected by varying the duty cycle of the power switch (Q1-Q4). The basic frequency at which the ± 150 V inputs are gated through T1 is established by the 20 kHz clock (E3). The 20 kHz clock is an astable multivibrator which generates a 20 kHz pulse output. The 20 kHz clock of the +2.5 V power supply is synchronized with the 20 kHz clock of the H7104 bias voltage power supply.

The 20 kHz pulse output of the clock (E3, pin 5) in conjunction with the output of the pulse width timer (Q4, E3, pin 9) limits the duty cycle of the power switch (Q1-Q4) to a maximum of approximately 46 percent. The actual duty cycle of the power switch (Q1-Q4) varies with output voltage fluctuations. (The nominal duty cycle of the power switch is approximately 30 percent; 15 μ s on and 35 μ s off.)

When the 20 kHz clock output goes high, the low to high transition resets the pulse width timer (Q4, E3) output to a high. The time that the output of the pulse width timer remains high is dependent upon the charge rate of C22. When the charge on C22 reaches the control voltage level, the timer is set and the charge on C22 is bled off. The level of the ± 2.5 V SENSE inputs to op amp (E5, pins 2 and 3) and the REF voltage inputs (pin 10) to comparator and op amp (E5) determine the rate at which C22 charges.

Diodes (D6 and D7) at the outputs of the 20 kHz clock (E3, pin 5) and the pulse width timer (E3, pin 9) form part of an OR gate which controls the power switch drivers (Q1, Q2). When either the 20 kHz clock or pulse width timer output is high, the power switch drivers are biased on and the charge developed across C14 during the power switch drivers off time is bled off (TRIGGER PULSE) through the primary of transformer (T2). (The charge C14 is developed during power switch (Q1-Q4) on time by the peak voltage, TURN-OFF DRIVE, sensed at one of the output windings of the output transformer, T1.) The induced voltages in the secondary of T2 bias the power switch (Q1-Q4) off. When both the 20 kHz clock and pulse width timer outputs are low, the power switch drivers (Q1, Q2) are turned off. When the power switch drivers are turned off, the induced polarity changes coupled across T2 bias the power switch (Q1-Q4) on. The ± 150 Vdc inputs to the power switch are coupled through the power switch providing a 300 Vdc INVERTER PULSE through the primary of transformer (T1). Transformer (T1) provides a low-voltage, high-current output at two secondary windings, which is rectified and filtered to produce the +2.5 Vdc, 8.5 to 85 A output. The voltage coupled through transformer (T1) is used also to produce the ± 30 Vdc outputs used as a power source for the ± 5 VB and +12 VB regulators. The power switch (Q1-Q4) remains on until the output of the 20 kHz clock goes high, which starts a new regulation cycle. The following timing diagram illustrates the timing relationship between the outputs of the 20 kHz clock and the pulse width timer (relative to the charge on C22), and the operation of the power switch driver (Q1, Q2) and the power switch (Q1-Q4).

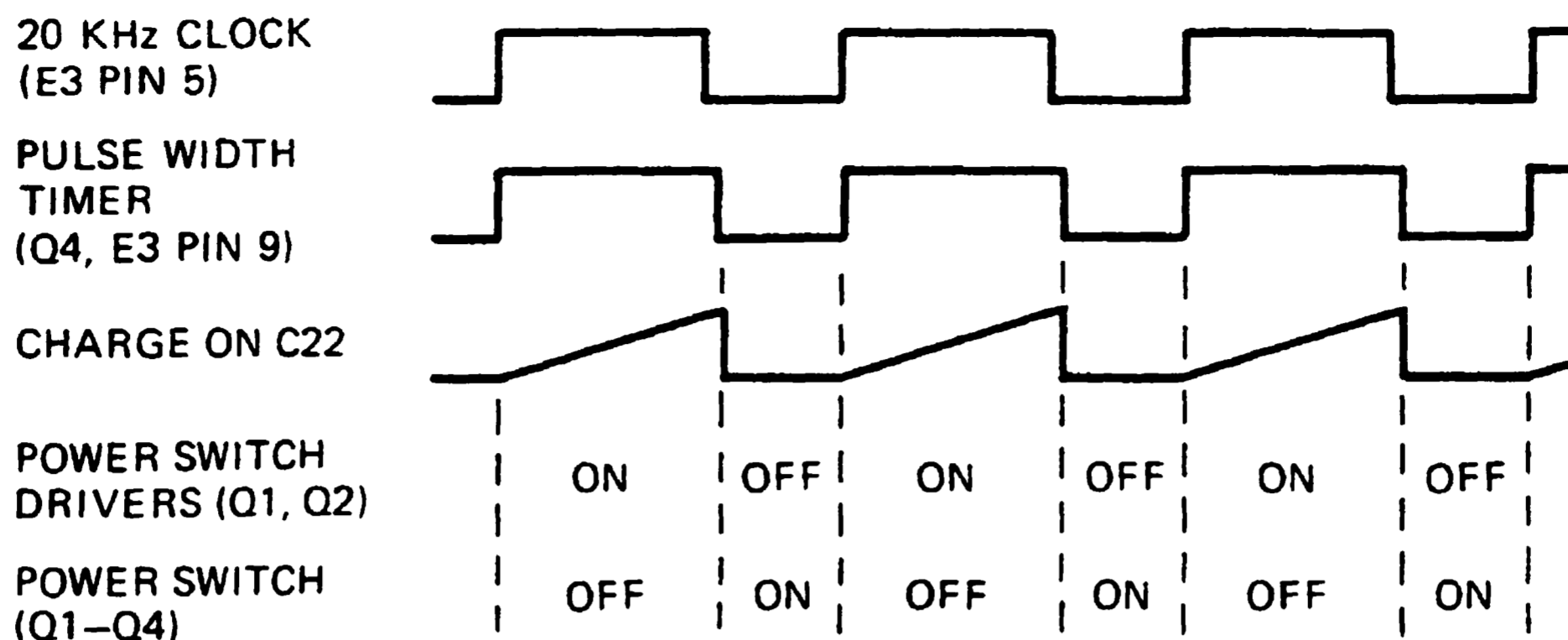

TK-5549

The ± 150 Vdc levels coupled through the power switch (Q1-Q4) provide INVERTER pulses of known current. The current flow through the power switch is sensed in transformer (T3). If a power switch failure causes pulses of higher current, the switch current detector (E4) resets the output of the pulse width timer to a high prior to the low-to-high transition output of the 20 kHz clock which normally resets the pulse width timer. This reduces the duty cycle of the power switch (Q1-Q4) and results in a decrease in voltage and power from the +2.5 V, 8.5 to 85 A output.

The output voltage of the +2.5 V power supply may be increased or decreased by 5 percent by way of the HI/NORMAL/LO switch (S1) on the output panel assembly. S1 and the margin control circuitry (E6, E7) on the 2.5 V control board decrease or increase the REF voltage input to comparator and op amp (E5). Changing the REF voltage input to E5 results in a change in the charge rate of C22, which increases or decreases duty cycle to provide the selected change in output voltage level. If the LO level condition is selected, a LO MARGIN signal is applied to the fault detect and status display circuitry to reduce the level at which the +2.5 V output initiates system shutdown (i.e., generates AC LO and DC LO resulting from a low level +V SENSE input.)

4.6.2.2 +2.5 V Overvoltage Protection – Overvoltage protection for the +2.5 V power supply is provided by the overvoltage detector and crowbar circuit on the output panel assembly. If an overvoltage condition occurs, the output of the power supply is shunted to ground and the operation of the power supply is inhibited for approximately 1/2 second. Then, the power supply is re-activated.

If the overvoltage threshold (approximately 3.3 V) is exceeded, an OVERVOLTAGE INDICATION is generated and the crowbar circuit is energized. The crowbar, when energized, immediately pulls the +2.5 V output level to approximately 0.7 V. When the current flow through the crowbar necessary to fully discharge capacitors C3 and C4 ceases, the crowbar is reset, allowing the +2.5 V output to be re-established. The OVERVOLTAGE INDICATION generated when the crowbar is energized is terminated when the crowbar is reset. OVERVOLTAGE INDICATION triggers the overvoltage restart one shot (E2) on the +2.5 V control board. The OVERVOLTAGE INDICATION is applied also to the fault detect and status display circuitry.

When triggered, the overvoltage restart one shot (E2) holds the slow run-up (Q16) on for a period of approximately 1/2 second. With Q16 on, the charge on C33 is bled off to ground, which clamps the REF input to comparator at a ground level. When Q16 is turned off, C33 gradually charges until it reaches the level of the REF voltage; a period of approximately 100 ms. Gradually increasing the level of the REF voltage results in a gradually increasing duty cycle of the power switch and gradual run-up of the +2.5 V output.

4.6.2.3 +2.5 V Overcurrent Protection – Overcurrent protection for the +2.5 V power supply is provided by sensing the current flow through the current sense resistor (R1) on the output panel assembly. The \pm CURRENT SENSE signals are detected in the overcurrent detector (E5) on the 2.5 V control board. If an overcurrent condition ($105\text{ A} \pm 15\%$) occurs, the overcurrent detector (E5) triggers the overcurrent restart one shot (E1). E1 effects power supply shutdown for a period of approximately 1/2 second and re-activates the power supply after the 1/2-second period as discussed in the preceding paragraph.

4.6.2.4 Low Level AC Input Protection – The operation of the +2.5 V power supply is inhibited during low ac line level conditions. The RAW DC OK and RELAY DRIVE OK inputs from the ac input and raw dc sections of the +2.5 V power supply assembly are high level signals whenever the potential difference between the $\pm 150\text{ Vdc}$ levels is less than approximately 200 V. The high RAW DC OK input turns on Q16 to effect slow run-up when the high RAW DC OK signal is terminated. The high RELAY DRIVE OK input inhibits the power switch drivers (Q1, Q2) as long as the RELAY DRIVE OK signal is applied.

4.6.2.5 +2.5 V Monitor Circuits – Monitor circuits (power switch detector, E4, and ac level detector, E4) peak sample the TURN OFF DRIVE signal. The peak voltage of the TURN OFF DRIVE signal is stored in capacitor (C11). If the stored level drops below approximately 90 V, the ac level detector generates a +2.5 V AC LOW signal. If the stored level drops below approximately 35 V, the power switch detector generates a +2.5 V POWER SWITCH FAIL signal. The +2.5 V POWER SWITCH FAIL and +2.5 V AC LOW outputs are applied to the fault detect and status display circuits.

4.7 5 VB REGULATORS

The $\pm 5\text{ VB}$ regulators of the +2.5 V power supply assembly converts the +30 Vdc input to regulated +5 VB dc, 2 to 20 A and -5 VB dc, 0 to 1.2 A outputs. Figure 4-7 is a functional block diagram of the $\pm 5\text{ VB}$ regulator. The following discussion is keyed to Figure 4-7 and engineering drawings 7016157, 7015856, 5413414, and 7015857.

During normal operation of the H7104 power system, the +30 Vdc input is the unregulated +30 Vdc output of the +2.5 V power supply. During power-down conditions resulting from a loss or low level condition of the ac facility power input to the H7104 power system, the dc power input to the $\pm 5\text{ VB}$ regulators is provided by the battery backup unit (if installed as an option). During normal operation, the bias and reference voltages are developed from the +12 VA bias voltage from the H7104 bias voltage power supply. During power-down conditions, the +12 VA input to the $\pm 5\text{ VB}$ regulators is backed up by the +12 VB output of the +12 VB regulator.

The +5 VB dc, 2 to 20 A and -5 VB dc, 0 to 1.2 A outputs are generated and regulated by controlling the duty cycle of the power switches which gate the +30 Vdc input into an inductive-capacitive network. Regulation of the outputs is effected by varying the duty cycle of the power switches. The basic frequency at which the +30 Vdc input is gated through the power switches is established by the 20 kHz clock (E2). E2 is an astable multivibrator which generates a 20 kHz pulse output. The 20 kHz clock of the $\pm 5\text{ VB}$ regulators is synchronized with the 20 kHz clock output of the H7104 bias voltage power supply. The 20 kHz output of the clock (E2) in conjunction with the pulse width timers of the $\pm 5\text{ VB}$ regulators (E3 and E6) limit the duty cycle of the power switches to a maximum of approximately 54 percent. The actual duty cycle of the power switches (i.e., approximately 50 percent) varies with the output voltage fluctuations due to changing load conditions.

When the +5 VB power switch (Q1, Q2, T2) is turned on, current flow is enabled through coil (L1) to charge capacitor (C4). When the power switch is turned off, current flow through L1 is maintained by flyback diode (D4) and discharge of capacitor (C4).

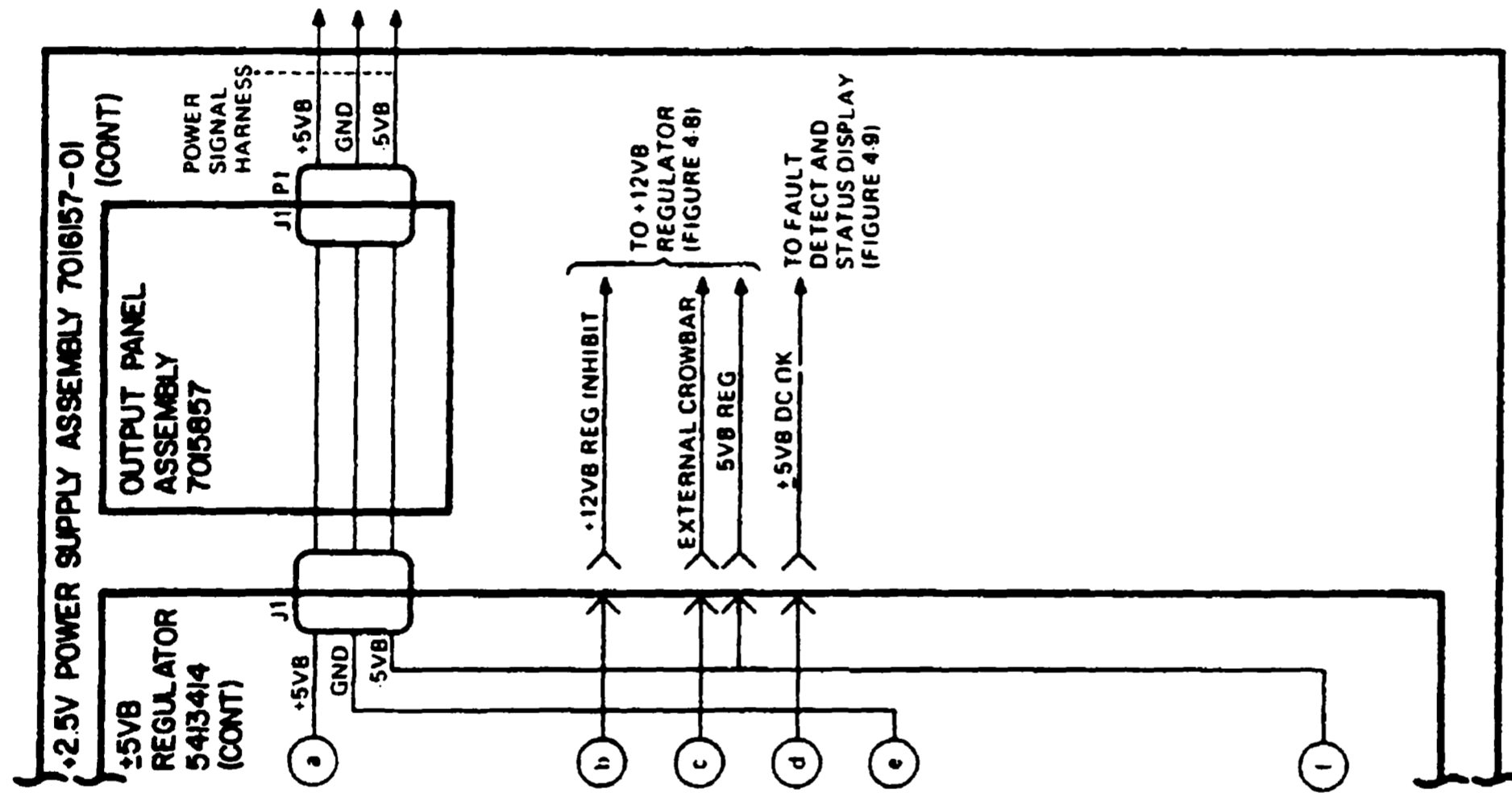

Figure 4-7 ±5 V Regulators Functional Block Diagram
(Sheet 2 of 2)

When the -5 VB power switch (Q12) is turned on, current flow is enabled through coil (L2). When the -5 VB power switch is turned off, the field about L2 collapses which forward biases diode (D19) and charges the output capacitor (C21). When the -5 VB power switch is turned on again, capacitor C21 discharges into the load.

4.7.1 Regulation of $+5$ VB, 2 to 20 A Output

Regulation of the $+5$ VB output is effected by varying the duty cycle of the $+5$ VB power switch (Q1, Q2, T2). The duty cycle of the $+5$ VB power switch is controlled by the outputs of the 20 kHz clock in conjunction with the output of the pulse width timer (E3). When the CLOCK output of the 20 kHz clock (E2) goes high, the $\overline{\text{CLOCK}}$ output goes low. The low-to-high transition of the CLOCK output enables reset driver (Q6) which, in turn, asserts a negative spike to the reset input of pulse width timer (E3). The low $\overline{\text{CLOCK}}$ signal is applied directly to the trigger input of E3. The negative spike and high-to-low transition of the $\overline{\text{CLOCK}}$ input reset the output of the pulse width timer to a low, which enables capacitor (C12) at the THRESH input of E3 to charge. The time that the output of the pulse width timer remains low is dependent upon the level of the V SENSE input to op amp (E4, Q7) relative to the REF voltage input. Op amp (E4, Q7) controls the charge rate of capacitor (C12). When the charge on C12 reaches the control voltage level, the pulse width timer output is set to a high. Capacitor C15 at the REF input provides for slow run-up of the REF voltage during initial power up and for smoothing response of the op amp to output voltage fluctuations.

The output of the pulse width timer and the $\overline{\text{CLOCK}}$ output of the 20 kHz clock control the power switch drivers (Q4, Q15). When either the $\overline{\text{CLOCK}}$ or pulse width timer output is low, the power switch drivers (Q4, Q5) are turned on. When Q4, Q5 are on, the charge developed across capacitor (C10) during the power switch drivers off time is bled off through the primary of transformer (T1). The induced voltages in the secondary of T1 bias the power switch (Q1, Q2, T2) off. When both $\overline{\text{CLOCK}}$ and pulse width timer outputs are high, the power switch drivers (Q4, Q5) are turned off. When Q4, Q5 are turned off, the induced polarity change in the secondary of T1 biases the power switch (Q1, Q2, T2) on. The power switch remains on until the $\overline{\text{CLOCK}}$ and/or pulse width timer output goes low. The following timing diagram illustrates the relationship between the $\overline{\text{CLOCK}}$ signal, the output of the pulse width timer (relative to the charge on C12), and the operation of the power switch drivers (Q4, Q5) and the power switch (Q1, Q2, T2).

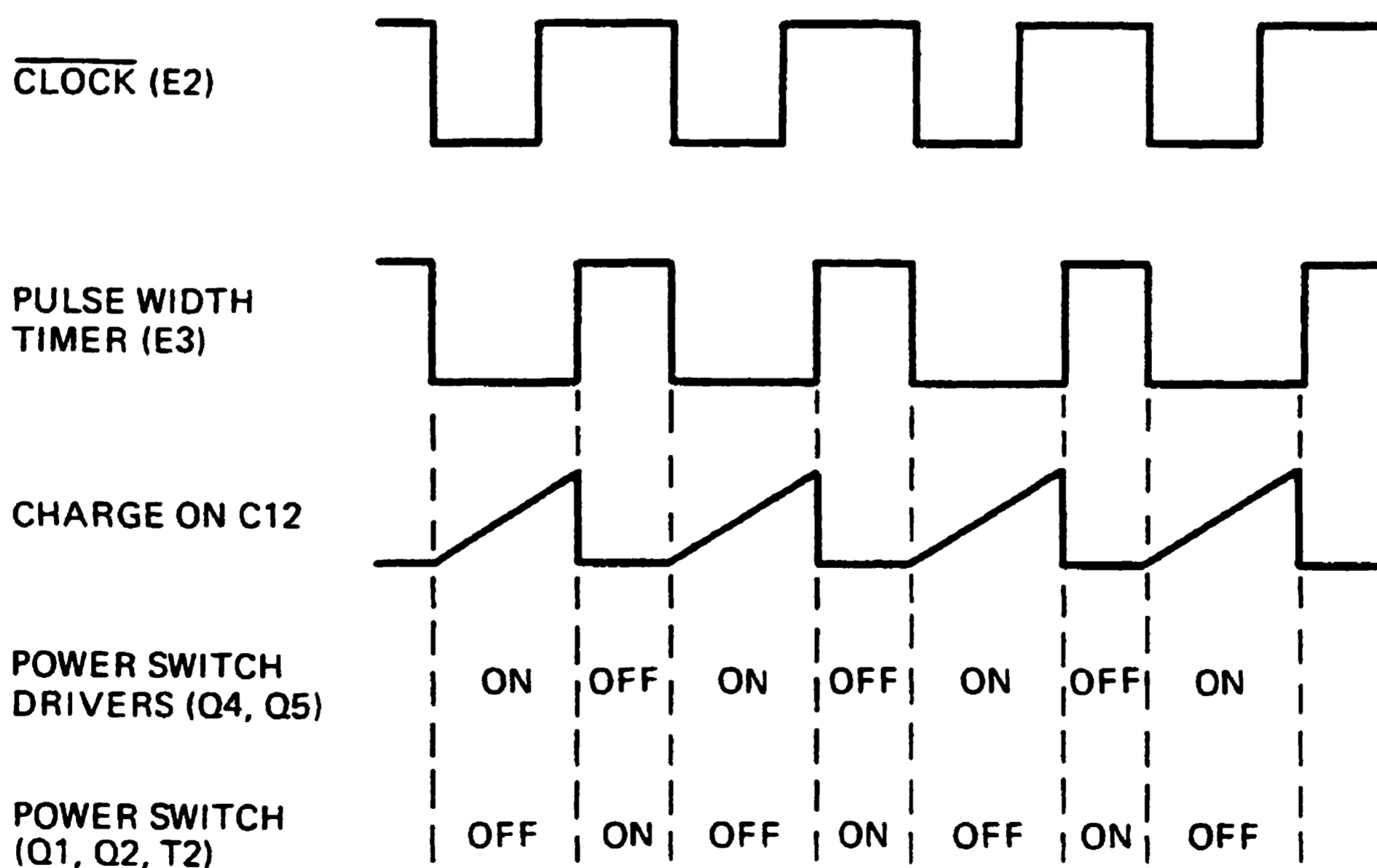

TK-5551

4.7.2 +5 VB Regulator Overcurrent Protection

Overcurrent protection for the +5 VB regulator is provided by overcurrent detector (E5). If an overcurrent condition ($24\text{ A} \pm 10\%$) occurs, the overcurrent detector (E5) resets the pulse width timer (E3) output to a low prior to the next low-to-high transition of the CLOCK output of the 20 kHz clock (E2). This shortens the duty cycle of the power switch resulting in a lower current and output voltage levels.

4.7.3 +5 VB Regulator Overvoltage Protection

Overvoltage protection for the +5 VB regulator is provided by the crowbar (D7, D8). If an overvoltage condition (approximately 6.8 V) occurs, the crowbar is enabled, which clamps the output of the +5 VB regulator at approximately 0.7 V.

4.7.4 Regulation of -5 VB, 0 to 1.2 A Output

Regulation of the -5 VB output is effected by varying the duty cycle of the -5 VB power switch (Q12). The duty cycle of the -5 VB power switch is controlled by the CLOCK output of the 20 kHz clock (E2) in conjunction with the output of the pulse width timer (E6). When the CLOCK output of the 20 kHz clock goes high, the CLOCK output goes low. The low-to-high transition of the CLOCK output enables reset driver (Q10), which, in turn, asserts a negative spike to the reset input of pulse width timer (E6). The low CLOCK signal is applied directly to the trigger input of (E6). The negative spike and high-to-low transition of the CLOCK inputs reset the output of E6 to a low and bleeds off the charge on capacitor (C20) at the THRESH input. The time that the output of the pulse width timer is low is dependent upon the voltage level output of op amp (E7), which is applied to the control voltage input of the pulse width timer. When capacitor C20 (fixed charge rate) charges to the control voltage level, the pulse width timer output is set to a high. Op amp (E7) responds to changes in output voltage level and raises or lowers the control voltage level input which extends or shortens, respectively, the time required to set the pulse width timer output to a high.

The output of the pulse width timer and the CLOCK output of the 20 kHz clock are combined in switch (Q13) to control the power switch driver (Q11) and power switch (Q12). When the CLOCK input to Q13 is low and the pulse width timer (E6) output is high, switch (Q13) turns on the power switch driver (Q11) and -5 VB power switch (Q12). Q11 and Q12 remain on until the CLOCK output of the 20 kHz clock (E2) goes high and/or the output of the pulse width timer (E6) goes low. The following timing diagram illustrates the relationship between the CLOCK signal, the pulse width timer output (relative to the control voltage input), and the operation of the power switch driver (Q11) and -5 VB power switch (Q12).

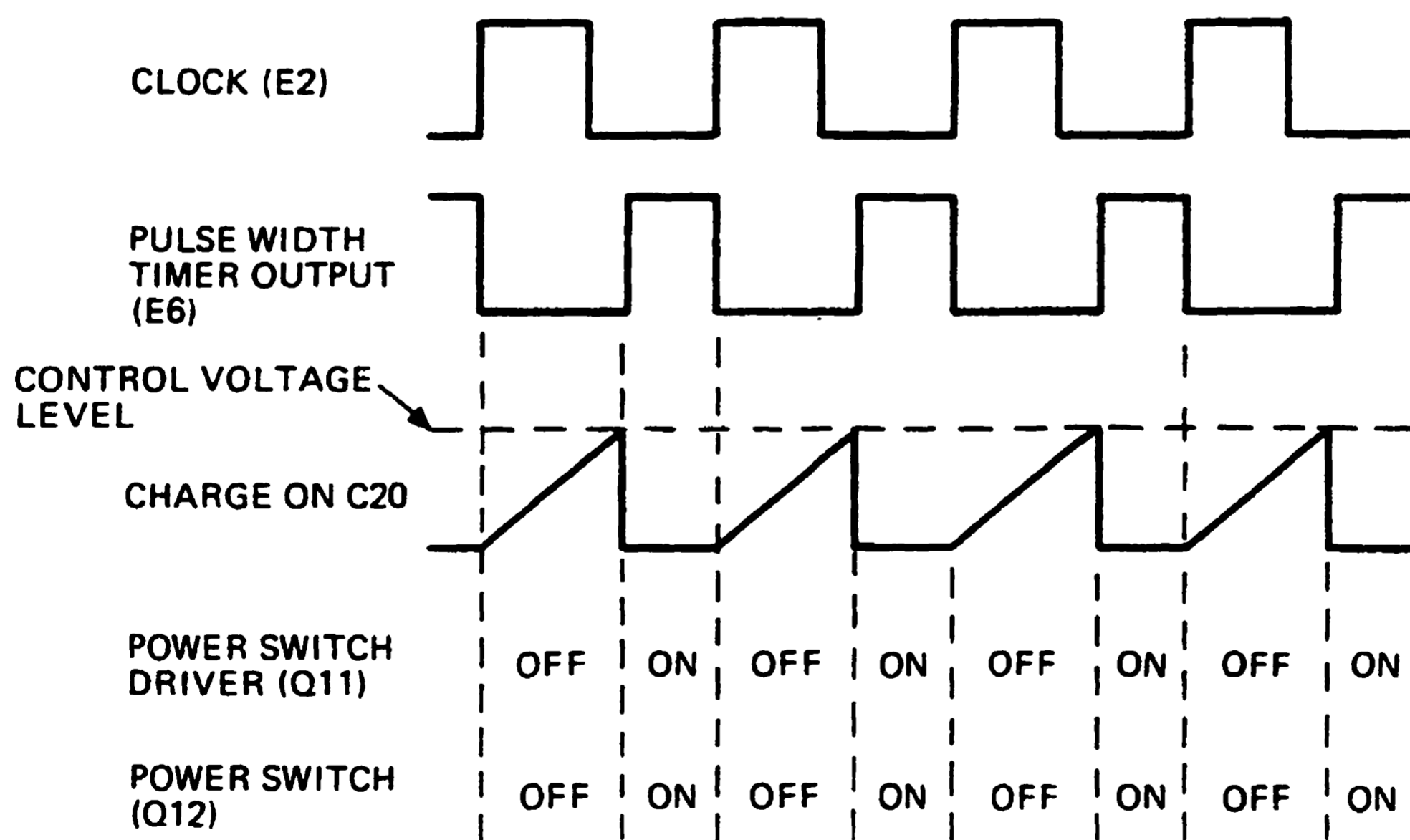

TK-5552

4.7.5 -5 VB Regulator Overcurrent Protection

Overcurrent protection for the -5 VB regulator is provided by reset driver (Q10). A voltage divider network in parallel to the normal current path provides a bias to Q10. If an overcurrent condition (1.44 A \pm 10%) occurs, the voltage divider network biases Q10 on, which resets the pulse width timer prior to the next low-to-high transition of the 20 kHz CLOCK signal. This shortens the duty cycle of the -5 VB power switch resulting in a lower current and output voltage level.

4.7.6 -5 VB Regulator Overvoltage Protection

Overvoltage protection for the -5 VB regulator is provided by the crowbar (D20-D22). If an overvoltage condition (approximately 6.8 V) occurs, the crowbar is enabled which clamps the output to -0.7 V.

4.7.7 5 VB Regulators Monitor Circuits

Monitor circuits, comparators and drivers (E5, Q8, Q9), sample the \pm 5 VB outputs and generate a +5 VB DC OK output if both outputs are within tolerance. If the -5 VB output goes low, the monitor circuits generate the +12 VB REG INHIBIT and EXTERNAL CROWBAR outputs which effect shutdown of the +12 VB regulator.

4.8 +12 VB REGULATOR

The +12 VB regulator of the +2.5 V power supply assembly converts the +30 Vdc input to a regulated +12 VB dc, 1 to 10 A output. Figure 4-8 is a functional block diagram of the +12 VB regulator. The following discussion is keyed to Figure 4-8 and engineering drawings 7016157, 5412556, and 7015857.

During normal operation of the H7104 power system, the +30 Vdc input is the unregulated +30 Vdc output of the 2.5 V power supply. During power-down conditions resulting from a loss or low level condition of the ac facility power input to the H7104 power system, the input power to the +12 VB regulator is provided by the battery backup unit (if installed as an option). During normal operation, the bias and reference voltages used by the +12 VB regulator are developed from bias voltages from the H7104 bias voltage power supply (i.e., the +12 VA, -12 VA, and +5 VA outputs). During power-down conditions, the bias and reference voltages are developed from the +12 VB output of the +12 VB regulator and the -5 VB output of the \pm 5 VB regulator. Isolation between the output voltages of the H7104 bias voltage power supply and the +12 VB and \pm 5 VB regulators is provided by diode buffers.

The +12 VB, 1 to 10 A output of the +12 VB regulator is generated by gating the +30 Vdc input through the power switch (Q1). Regulation of the +12 VB output is effected by varying the duty cycle of the power switch relative to the sampled output voltage level. When the power switch is turned on, current flow is enabled through coil (L1) to charge capacitor (C14). When the power switch is turned off, current flow through L1 is maintained by flyback diode (D10) and discharge of capacitor (C14).

4.8.1 Regulation of +12 VB, 1 to 10 A Output

Regulation of the +12 VB output is effected by varying the duty cycle of the power switch (Q1). The basic frequency at which the +30 Vdc input is gated through the power switch is established by the 20 kHz clock (E1). E1 is an astable multivibrator which generates a 20 kHz pulse output. The 20 kHz clock of the +12 VB regulator is synchronized with the 20 kHz clock of the H7104 bias voltage power supply. The 20 kHz output of the clock (E1), in conjunction with the output of the pulse width timer (E2), limits the duty cycle of the power switch to a maximum of approximately 70 percent. The actual duty cycle of the power switch varies with output voltage fluctuations due to changing load conditions. (The nominal duty cycle of the power switch is approximately 50 percent; 25 μ s on and 25 μ s off.)

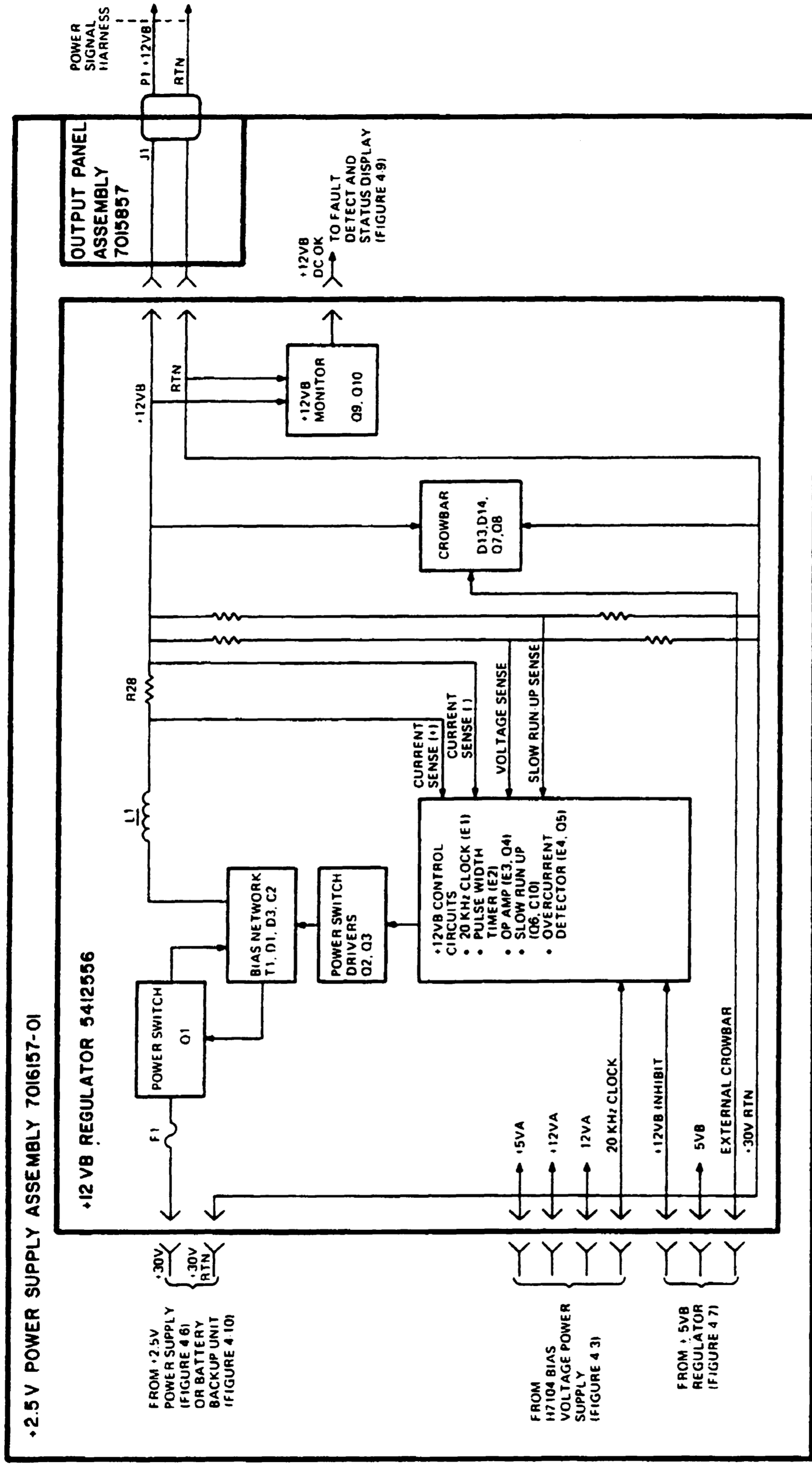

PK 5564

Figure 4-8 +12V Regulator Functional Block Diagram

When the 20 kHz clock output goes low, the high-to-low transition sets the pulse width timer output to a low and bleeds off the charge on capacitor (C8) which is connected to the threshold input of the pulse width timer. The amount of time that the pulse width timer remains low is dependent upon the level of the VOLTAGE SENSE input to op amp (E3, Q4). Op amp (E3, Q4) controls the charge rate of capacitor (C8). Changing the charge rate of C8 effects the time required to set the output of the pulse width timer to a high. When the charge on C8 reaches the control voltage level, the pulse width timer output is set to a high. The outputs of the pulse width timer and 20 kHz clock control the power switch drivers (Q2, Q3). If the 20 kHz clock output or pulse width timer output is low, the power switch drivers are turned on and the charge developed across capacitor (C2) during the power switch drivers' off time is bled off through the primary of transformer (T1). The induced voltages in the secondary of T1 biases the power switch (Q1) off. When both the 20 kHz clock and pulse width timer outputs are high, the power switch drivers (Q2, Q3) are turned off. When Q2, Q3 are turned off, the induced polarity changes coupled across T2 bias the power switch (Q1) on. Q1 remains on until the output of the 20 kHz clock and/or the pulse width timer output goes low. The following timing diagram illustrates the relationship between the outputs of the 20 kHz clock and pulse width timer (relative to the charge on C8), and the operation of the power switch drivers (Q2, Q3) and power switch (Q1).

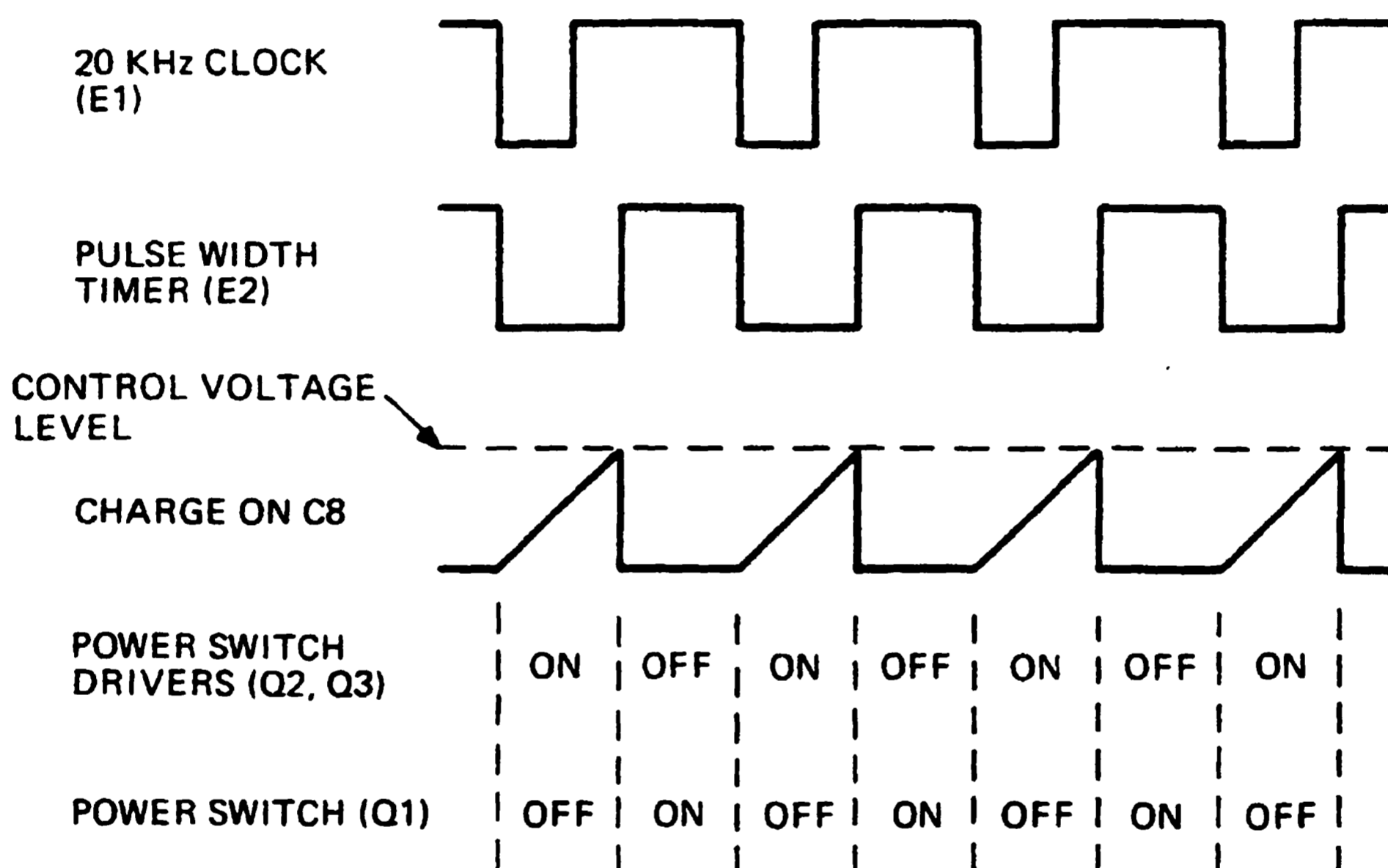

TK-5553

The slow run-up (Q6, C10) controls the REF voltage input to op amp (E3, Q4). The slow run-up slowly increases the REF input level during initial power up to prevent overshoot in the +12 VB output and to smooth out the response of the op amp to output voltage fluctuations.

4.8.2 +12 VB Regulator Overcurrent Protection

Overcurrent protection for the +12 VB regulator is provided by overcurrent detector (E4, Q5). If an overcurrent condition ($12\text{ A} \pm 10\%$) occurs, the overcurrent detector (E4, Q5) resets the pulse width timer output to a low prior to the next high to low transition of the 20 kHz clock input. This shortens the duty cycle of the power switch resulting in a lower current and output voltage level.

4.8.3 +12 VB Regulator Overvoltage Protection

Overvoltage protection is provided by the crowbar (D13, D14, Q7, Q8). If an overvoltage condition occurs (output potential exceeds approximately 15 V), the crowbar will be enabled and the output of the +12 VB regulator will be clamped at approximately 0.7 V. The EXTERNAL CROWBAR and +12 VB INHIBIT signal inputs to the +12 VB regulator are common. These inputs are generated to inhibit the +12 VB regulator if the -5 VB output of the ± 5 VB regulator is inhibited. This prevents damage to the components which operate from the +12 VB and -5 VB dc voltages. The +12 VB INHIBIT signal holds the power switch drivers on which inhibits the power switch (Q1). The EXTERNAL CROWBAR input from the ± 5 VB regulator enables the +12 VB crowbar circuit which clamps the output of the +12 VB regulator at approximately 0.7 V. The crowbar (D13, D14, Q7, Q8) may be reset by removing and re-applying power to the H7104 power system.

4.8.4 +12 VB Regulator Monitor Circuit

A monitor circuit (Q9, Q10) samples the +12 VB output and generates a low +12 VB DC OK status signal output if the potential at the +12 VB output drops below approximately 10.5 V.

4.9 FAULT DETECT AND STATUS DISPLAY

The fault detect and status display circuitry monitors the status signal and operational outputs of the power supplies and regulators and drives indicators on the power controller status card and the control panel. The status card and control panel indicators provide visual display of operational status. Additionally, the fault detect and status display circuitry generates AC LO, DC LO, and BATTERY BACKUP ENABLE signals during normal power-down sequence or in the event of an H7104 power system failure. The AC LO and DC LO outputs are applied to the CPU and UNIBUS option backplanes. During normal power-down sequences, there is a minimum of 5 ms between the occurrence of the AC LO and DC LO outputs. The BATTERY BACKUP ENABLE output occurs simultaneously with the AC LO output. Figure 4-9 is a functional block diagram of the fault detect and status display circuitry. The following description is keyed to Figure 4-9 and engineering drawings 7016156, 5413382, 7016157, 5413396, 7015857 7015929, 5413392, and E-IC-H7104.

The operational outputs of the power supplies include the +5 V SENSE and LO MARGIN outputs of the +5 V power supply, and the 2.5 V SENSE and LO MARGIN outputs of the ac input, raw dc, and +2.5 V power supply.

The +5 V SENSE and LO MARGIN outputs of the +5 V power supply are applied to the +5 V monitor circuit on the +5 V control board. The +5 V monitor circuit generates a low +5 V DC OK output if the +5 V SENSE signal falls below 4.75 V. The LO MARGIN input to the +5 V monitor inhibits generation of the low +5 V DC OK output when the HI/NORMAL/LO switch on the +5 V power supply is set at the LO position.

The 2.5 V SENSE and LO MARGIN outputs of the ac input, raw dc, and +2.5 V power supply are applied to the dc monitor circuit on the 2.5 V control board. The dc monitor circuit generates a low DC FAIL output if the 2.5 V SENSE signal falls below approximately 2.2 V. When the HI/NORMAL/LO switch on the +2.5 V power supply assembly is set at the LO position, the LO MARGIN signal (GND) changes the reference at the input of the dc monitor such that the DC FAIL output is generated only if the 2.5 V SENSE signal falls below approximately 2.0 V.

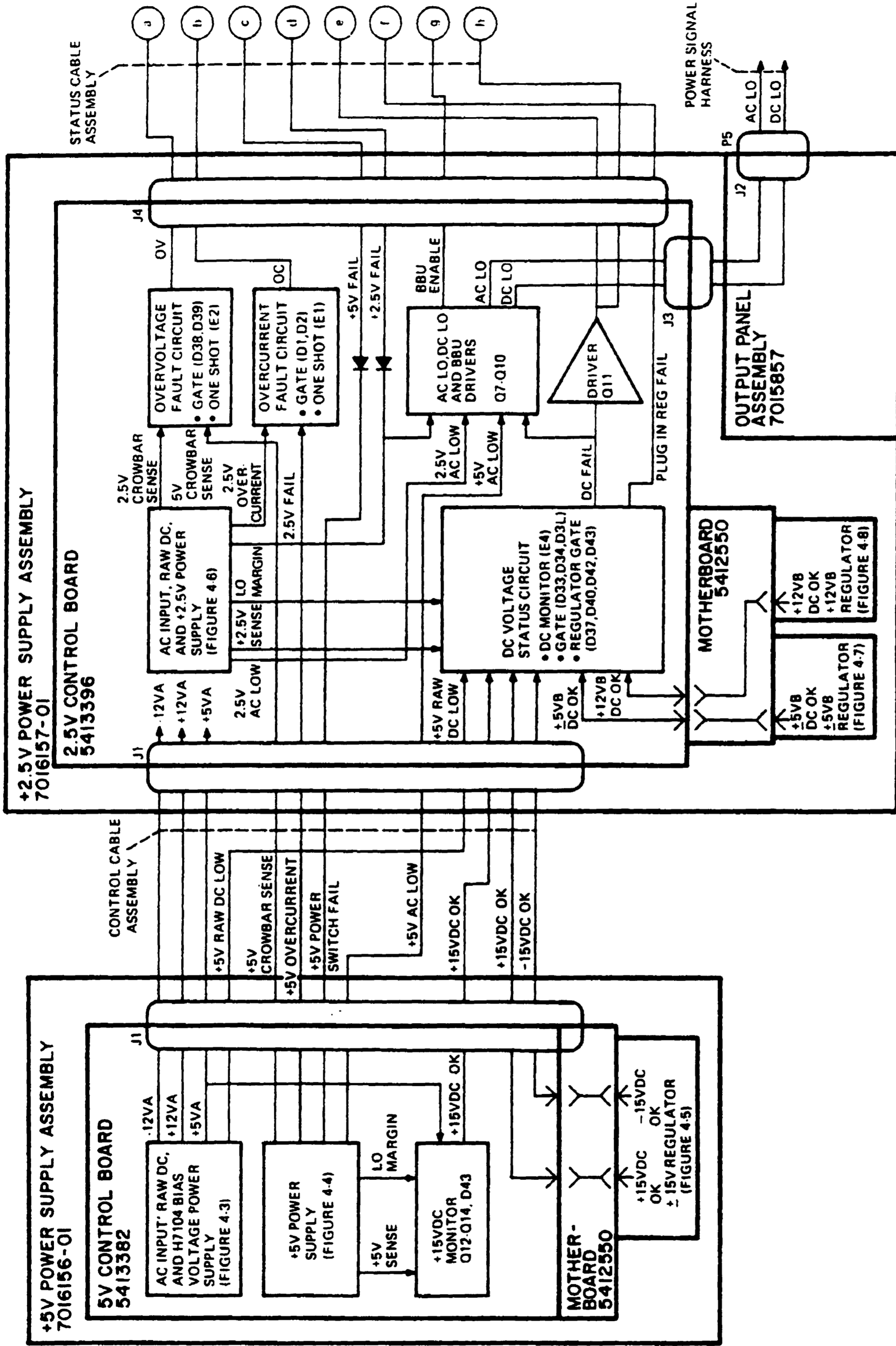

TK 5586

Figure 4-9 Fault Detect and Status Display Functional Block Diagram (Sheet 1 of 2)

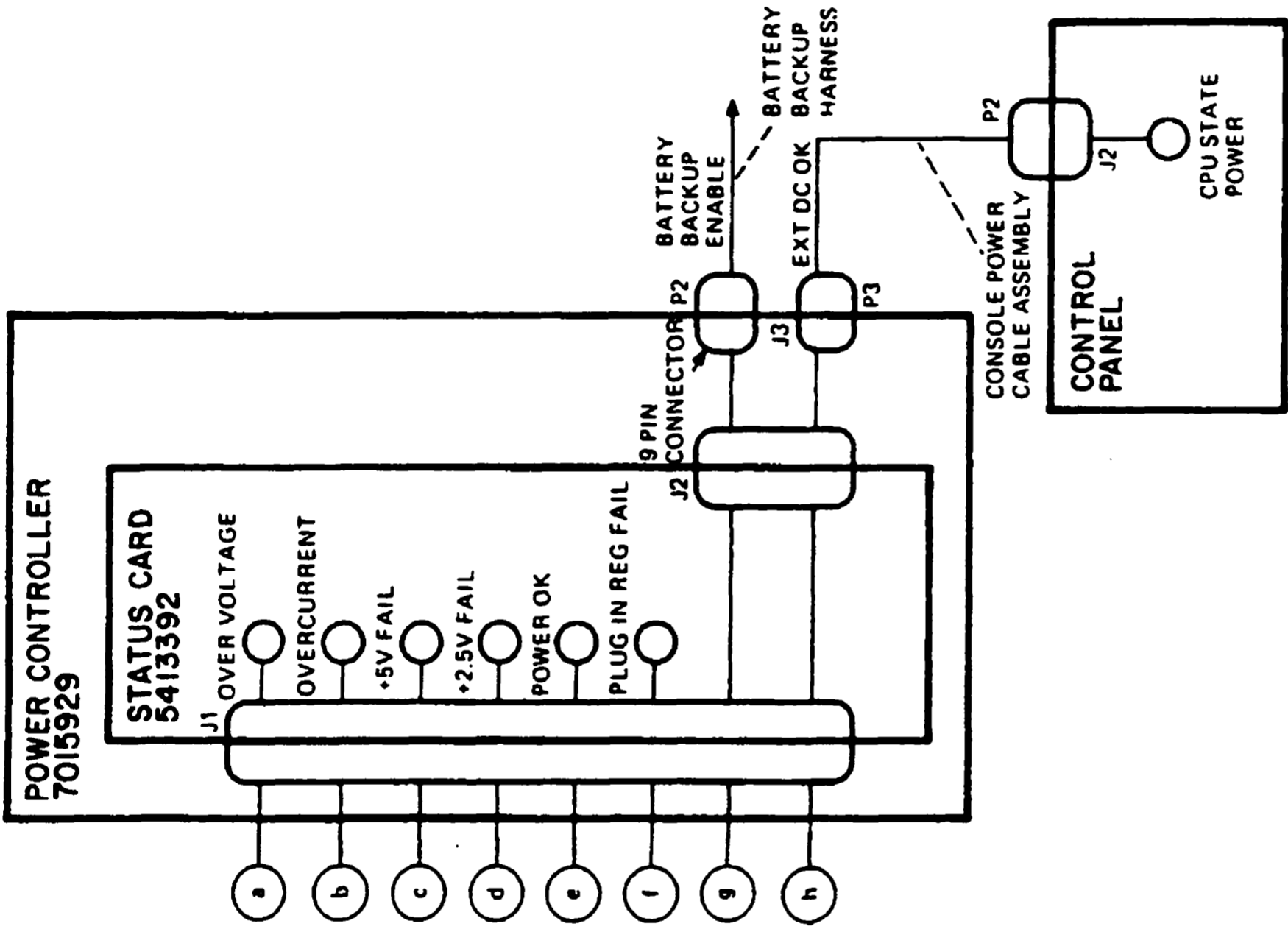

Figure 4-9 Fault Detect and Status Display Functional Block Diagram (Sheet 2 of 2)

During normal power-down conditions, the 2.5 V AC LO or +5 V AC LO inputs to driver (Q10) on the 2.5 V control board will go low a minimum of 5 ms before any of the output voltages falls below its specified rating. The low 2.5 V AC LO or +5 V AC LO input enables driver (Q10) which asserts a -12 V to GND level BATTERY BACKUP ENABLE signal to the battery backup unit. The GND level output of Q10 also turns on field effect transistor (FET) (Q8) which asserts a low AC LO signal to the CPU and UNIBUS option backplanes. When any of the output voltages falls below its specified rating, the applicable DC OK output is set to a low; that is, except for the 2.5 V output of the ac input, raw dc, and +2.5 V power supply. The low level limit of the +2.5 V output is detected in the dc monitor circuit which also is driven by the DC OK outputs of the power supplies and regulators. The DC OK outputs of the power supplies and regulators are ANDed and coupled to the 2.5 V SENSE input to the dc monitor circuit. Any low DC OK input or low level 2.5 V SENSE input enables the dc monitor, which produces a low DC FAIL output. The low DC FAIL signal enables driver (Q9), which, in turn, enables FET (Q7) producing a low level DC LO output.

If, during normal operation, a fault condition should develop in any of the power supplies or regulators, the applicable status signal outputs initiate the AC LO, DC LO, and BATTERY BACKUP ENABLE outputs and drive indicators on the control panel and power controller status card to indicate the detected failure. However, during a fault condition the AC LO, DC LO, and BATTERY BACKUP ENABLE outputs are generated simultaneously (i.e., there is not a 5 ms delay between the AC LO and DC LO outputs). Table 4-2 indicates the active status signal outputs versus fault condition and the fault status display associated with each fault condition.

It is not possible to define accurately the fault status display associated with fault conditions in the ac input, raw dc, and H7104 bias voltage power supply, since the voltages developed are used throughout the H7104 power system. However, the most probable indication of failure in the ac input, raw dc, and H7104 bias voltage power supply is that none of the status indicators illuminate.

4.10 TIME-OF-YEAR BATTERY

The time-of-year battery unit, located on the vertical frame member above and to the right of the +5 V power supply assembly as viewed from the rear of the cabinet, comprises four 1.25 V nickel cadmium batteries connected in series. These batteries provide operating power (5 V @ 6 mA) via CPU backplane connector J5 to the time-of-year counter on the UNIBUS interconnect module for a period of approximately 100 hours during power-down conditions (i.e., during normal shutdown or during power outages). The batteries are charged during normal periods of operation by the time-of-year battery charger. (Refer to *VAX-11/750 Technical Description*, EK-KA750-TD, for the operation of the time-of-year battery charger.)

Table 4-2 Fault Conditions Versus Status Display

Fault Condition/ Active Status Signals	Status Card Indicator					Reg Fail	CPU State/ Power Indicator
	Overvoltage	Overcurrent	+5 Fail	+2.5 Fail	Power OK		
+2.5 V OVERVOLTAGE/ +2.5 V CROWBAR SENSE +2.5 V AC LOW +2.5 V POWER SWITCH FAIL +2.5 V SENSE	ON	OFF	OFF	ON	OFF	ON	OFF
+5 V OVERVOLTAGE/ +5 V CROWBAR SENSE +5 V AC LOW +5 V POWER SWITCH FAIL +5 V DC OK	ON	OFF	ON	OFF	OFF	ON	OFF
+2.5 V OVERCURRENT/ +2.5 V OVERCURRENT +2.5 V AC LOW +2.5 V POWER SWITCH FAIL +2.5 V SENSE	OFF	ON	OFF	ON	OFF	ON	OFF
+5 V OVERCURRENT/ +5 V OVERCURRENT +5 V AC LOW +5 V POWER SWITCH FAIL +5 V DC OK	OFF	ON	ON	OFF	OFF	ON	OFF
ANY PLUG IN REGULATOR/ APPLICABLE DC OK	OFF	OFF	OFF	OFF	OFF	ON	OFF

4.11 BATTERY BACKUP UNIT, H7112

The battery backup unit provides power (27 to 47 Vdc) to the ± 5 VB and +12 VB regulators in the +2.5 V power supply assembly to maintain the +5 VB, -5 VB, and +12 VB dc outputs during system power-down conditions resulting from a loss or low level condition of the 120/240 Vac facility power. During normal periods of system operation, the battery backup unit functions as a battery charger. Figure 4-10 is a functional block diagram of the battery backup unit and the interface with the control panel, and power controller. As shown, the battery backup unit comprises three 12 V lead-acid rechargeable batteries, ac bracket assembly, and battery charger.

There are four configurations of battery backup units which may be used with the H7104 power system. The configuration used is determined by the ac facility power input from which the unit must operate. Configuration versus ac facility power input is as follows:

1. H7112A 115 V, 60 Hz
2. H7112B 230 V, 50 Hz
3. H7112C 115 V, 50 Hz
4. H7112D 230 V, 60 Hz

Although there are several configuration differences between the four configurations, the following functional description is applicable to all configurations. The following discussion is keyed to Figure 4-10 and engineering drawings 7014122, 5412675, and 7015929.

The battery backup unit is controlled by the POWER ON/OFF switch on the battery backup unit and the five-position keyswitch on the control panel. The battery backup unit is enabled when the POWER ON/OFF switch is set to ON and the five-position keyswitch on the control panel is set to a position other than OFF. The function (i.e., battery charger or battery power source for the ± 5 VB and +12 VB regulators in the +2.5 V power supply assembly) performed by the battery backup unit is dependent upon the condition of the BATTERY BACKUP ENABLE signal input from the fault detect and status display circuitry. When the BATTERY BACKUP ENABLE signal is asserted, the 27 to 47 Vdc output from the batteries is coupled to the ± 5 VB and +12 VB regulators in the +2.5 V power supply assembly. When the BATTERY BACKUP ENABLE signal is not asserted, the battery backup unit functions as a battery charger.

4.11.1 Battery Charger Functional Description

The ac input from the power controller is coupled through the POWER ON/OFF switch and applied to transformer (T1). T1 is configured as a magnetic regulator. Capacitor (C1) in one of the secondary windings holds the secondary at saturation to effect regulation of the ac signal applied to the rectifier and filter on the battery charger. The rectifier and filter converts the ac signal input to a +50 to +70 Vdc level.

The +15 V used as a bias voltage on the battery charger is developed by the current path through zener (D15) and diode D31 to the +50 to +70 Vdc output of the rectifier and filter. The bias voltage to turn on relay driver (Q4) is developed by the current path through zener (D16) and diode (D13). Relay driver (Q4) effects closure of relay (K1). (K1 can only be energized when the POWER ON/OFF switch on the battery backup unit is set at ON and the five-position keyswitch on the control panel is set at a position other than OFF.) As shown in Figure 4-10, the current path for energizing K1 is through the two switches mentioned previously and diode (D13) to the output of the rectifier and filter. When K1 is energized, the batteries are charged by the current flow through relay (K1), diode (D12), current source (Q1), and K1 to the +50 to +70 V output of the rectifier and filter. When the battery backup unit is initially turned on, the fast charge driver (Q2, D29) turns on the 500 mA current source (Q1).

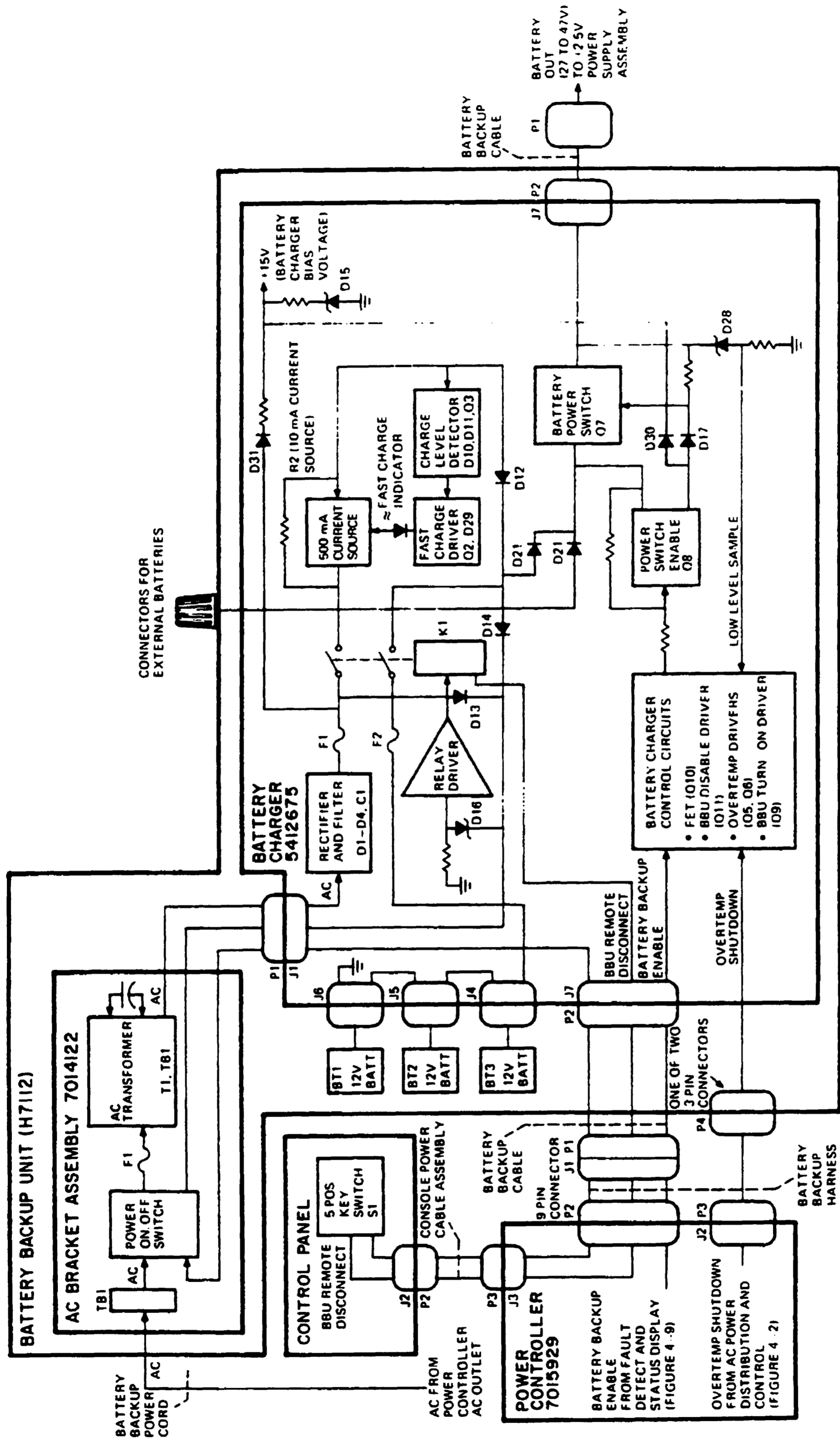

Figure 4-10 Battery Backup Unit Functional Block Diagram

While the 500 mA current source is enabled, an LED (D6) illuminates to indicate that the battery charger is operating in the fast charge mode. (The fast charge indicator is located on the battery charger board and may be seen only by looking through the cooling slots of the battery backup unit.) When the batteries have charged to approximately 40 V, the charge level detector (D10, D11, Q3) inhibits the fast charge driver, which, in turn, inhibits the 500 mA current source. Thus, the charge path is through R2, a 10 mA current source. (Note that the charge level detector enables the fast charge driver and 500 mA current source during initial system turn-on only. That is, once the 500 mA current source is inhibited after the batteries have been charged to approximately 40 V, the fast charge current source cannot be turned on for the remainder of the system operating cycle. Thus, the battery backup remains in the trickle charge mode.)

4.11.2 Battery Power Source Functional Description

The battery power source function of the battery backup unit is enabled by the BATTERY BACKUP ENABLE signal input from the fault detect and status display circuitry. When the battery power source function is enabled, the battery backup unit provides battery power (27 to 47 Vdc) to the ± 5 VB and +12 VB regulators in the +2.5 V power supply assembly to maintain the +5 VB, -5 VB, and +12 VB dc outputs. Upon loss or low level condition of the ac power source, the fault detect and status display circuitry switches the BATTERY BACKUP ENABLE signal input from -12 V to a GND level. The GND level BATTERY BACKUP ENABLE signal enables FET (Q10), which, in turn, inhibits the BBU disable driver (Q11). The output of Q11 is ANDed with the OVERTEMP SHUTDOWN and LOW BATTERY LEVEL signals in diode network (D22-D25) at the input of the BBU turn on driver (Q9). The OVERTEMP SHUTDOWN signal inhibits the battery backup function if the loss of ac power resulted because of an overtemperature condition. The LOW BATTERY LEVEL signal inhibits the battery backup function after the batteries have been discharged to approximately 27 V. When the BBU disable driver (Q11) is inhibited and NO OVERTEMP SHUTDOWN or LOW BATTERY LEVEL signal is present, the BBU turn-on driver (Q9) establishes a current path from ground through a voltage divider, diode (D21), and relay (K1) to the plus voltage output of the batteries. (Relay (K1) is held energized during a low level condition or ac power loss by the alternate current path provided by diode (D14).) The current path established by the BBU turn-on driver (Q9), provides the bias to turn on power switch enable (Q8). Q8 establishes two current paths: one through diode (D30) which maintains the +15 V battery charger bias voltage, and one through diode (D17) which provides the bias voltage to turn on the battery power switch (Q7). Q7 couples the output of the batteries to the ± 5 VB and +12 VB regulators in the +2.5 V power supply assembly.

As shown in Figure 4-10, external batteries may be connected to the battery backup unit to extend the interval (minimum of 10 minutes) in which the batteries maintain the ± 5 VB and +12 VB outputs. No charge capability is provided for the external batteries. If external batteries are connected, overcurrent protection (15 A fuse) must be provided. External batteries must provide 30 to 48 V at 260 W. The batteries recommended for external use are the 12 V sealed lead-acid batteries (three required), DEC Part Number 1212499-00.

4.12 DC POWER DISTRIBUTION

The dc voltage outputs of the H7104 power system are distributed to the CPU and UNIBUS modules and to the TU58 controller board via the backplane connectors. The dc voltage and power requirements for the CPU and UNIBUS modules are outlined in Table 4-3. The dc voltage and power requirements for the TU58 controller board are as follows: +5 V at 0.75 A maximum, +12 VB at 1.2 A maximum.

Table 4-3 DC Power Distribution and Approximate Power Requirements for VAX-11/750 Modules

Slot*	Module	Power Requirements (Amps)					Total Power (Watts)
		+2.5 V	+5 V	+5 VB	+12 VB	+15 V	
1**	Floating-Point Accelerator (FPA)	14.0	10.0	-	-	-	85
2	Data Path Module (DPM)	11.0	10.0	-	-	-	77.5
3	Micro Interconnect Module (MIC)	9.0	10.0	-	-	-	72.5
4	UNIBUS Interconnect Module (UBI)	3.5	7.0	-	1.3	0.05	60.1
5	COMET Control Store (CCS)	-	14.0	-	-	-	70
**	Writable Control Store (WCS)	-	3.5	-	-	-	17.5
6†	Remote Diagnosis Module (RDM)	-	12.0	-	0.1	0.1	62.7
7**	Option 1	6.0	12.0	-	-	-	76.5
8**	Option 2	6.0	12.0	-	-	0.3	76.5
9**	Option 3	6.0	12.0	-	-	0.3	76.5
10	COMET Memory Controller (CMC)	4.0	3.5	5.0	-	-	52.5
11	Memory Array	-	0.5	0.6	2.5	0.02	35.6
12**	Memory Array	↔	↔	↔	↔	↔	↔
18**	Memory Array	↔	0.5	0.6	2.5	0.02	↔
19**	UNIBUS Jumper	-	-	-	-	-	-
20**	UNIBUS Jumper	-	-	-	-	-	-
21**	UNIBUS	-	Vartt	-	-	-	Vartt
28**	UNIBUS	↔	(25 Total) ↔	↔	(2.0 Total) ↔	(3.4 Total) ↔	Vartt

* Slot number: right to left from front of cabinet

** Optional module

† RDM for field service use only

†† Maximum power available for UNIBUS options plugged into the DD11-DK located within the VAX-11/750 cabinet



CHAPTER 5

FAULT ISOLATION PROCEDURES AND REMOVAL AND REPLACEMENT INSTRUCTIONS

5.1 FAULT ISOLATION

The CPU STATE/POWER indicator on the control panel and the controls and indicators on the power controller provide visual indications of H7104 power system status (i.e., operational or fault condition). The fault indications provided by the controls and indicators may be used to aid in fault isolation.

Figure 5-1 illustrates the various combinations of indicator/control conditions which indicate a fault within the H7104 power system or in an associated assembly. To isolate a fault to a replaceable assembly, match the observed control/indicator condition to the possible conditions outlined in Figure 5-1. For each condition of Figure 5-1, the faulty assembly is identified or a fault isolation procedural reference (IDENT.) is provided.

The fault isolation procedures of Table 5-1 are provided as a guide in fault isolation to a replaceable unit or to identify a specific area of fault. Perform only those procedures of Table 5-1 which are referenced from Figure 5-1 (i.e., if IDENT. B is referenced in Figure 5-1, the procedures identified as Ident. B1 through B7 of Table 5-1 contain the applicable fault isolation procedures). Perform all procedural instructions of the first referenced Ident. (i.e., Ident. B1 if IDENT. B is referenced). Then, match the indication observed with the indications provided in the Indication column of the specific Ident. Then, perform the action (Action column) associated with the observed indication.

	CONTROL PANEL		POWER CONTROLLER									POSSIBLE FAULT AREA(S)	FAULTY ASSEMBLY OR FAULT ISOLATION PROCEDURAL REFERENCE TO TABLE 5-1.	
	FIVE POSITION KEYSWITCH	CPU STATE/ POWER	POWER	CIRCUIT BREAKER	REMOTE/OFF/LOCAL	POWER OK	OVER TEMP	OVER VOLTAGE	OVER CURRENT	+5 FAIL	+2.5 FAIL			REG FAIL
CONDITION	ON+	OFF	OFF	*	*	*	*	*	*	*	*	*	AC POWER	IDENT. A
	ON	OFF	ON	OFF	*	*	*	*	*	*	*	*	AC LOAD OR AIR FLOW	IDENT. B
	ON	OFF	ON	ON	REM	ON	*	*	*	*	*	*	STATUS SIGNAL	IDENT. C
	ON	OFF	ON	ON	REM	OFF	OFF	OFF	OFF	OFF	OFF	OFF	OVERTEMP, POWER CONTROLLER, POWER SUPPLY, OR CONTROL SIGNAL	IDENT. D
	ON	OFF	ON	ON	REM	OFF	ON	OFF	OFF	OFF	OFF	OFF	OVERTEMP, POWER SUPPLY	IDENT. E
	ON	OFF	ON	ON	REM	OFF	OFF	ON	OFF	ON	OFF	ON	+5V POWER SUPPLY	+5V POWER SUPPLY
	ON	OFF	ON	ON	REM	OFF	OFF	ON	OFF	OFF	ON	ON	+2.5V POWER SUPPLY	+2.5V POWER SUPPLY
	ON	OFF	ON	ON	REM	OFF	OFF	OFF	ON	ON	OFF	ON	+5V POWER SUPPLY OR LOAD	IDENT. F
	ON	OFF	ON	ON	REM	OFF	OFF	OFF	ON	OFF	ON	ON	+2.5V POWER SUPPLY OR LOAD	IDENT. G
	ON	OFF	ON	ON	REM	OFF	OFF	OFF	OFF	ON	OFF	ON	+5V POWER SUPPLY	+5V POWER SUPPLY
	ON	OFF	ON	ON	REM	OFF	OFF	OFF	OFF	OFF	ON	ON	+2.5V POWER SUPPLY	+2.5V POWER SUPPLY
ON	OFF	ON	ON	REM	OFF	OFF	OFF	OFF	OFF	OFF	ON	REGULATOR OR LOAD	IDENT. H	

+ SET AT ANY POSITION OTHER THAN OFF.
 *DON'T CARE CONDITION.
 ++REM=REMOTE POSITION.

Figure 5-1 H7104 Power System Fault Isolation Guide

Table 5-1 Fault Isolation Procedure

Ident.	Procedure	Indication	Action
A	Verify presence of facility power at facility power outlet.	Facility power is present.	Remove and replace power controller.
		Facility power is not present.	Facility power fault.
B1	Check airflow path for obstructions.	Obstructions present.	Clear obstructions from airflow path.
		No obstructions present.	Proceed to Ident. B2.
B2	Disconnect airflow patch cable connector P1 from J1 of the power controller. Set circuit breaker, CB1, to ON position.	Blower motor operates and CB1 remains ON.	Remove and replace airflow sensor. If fault persists remove and replace airflow patch cable.
		Blower motor does not operate and CB1 trips to OFF.	Proceed to Ident. B3.
B3	Connect airflow patch cable connector P1 to J1 of the power controller. Disconnect blower cord assembly from ac outlet on power controller. Set circuit breaker CB1 to ON position.	CB1 remains ON for approx. 30 sec, then trips to OFF.	Remove and replace blower motor assembly. If fault persists remove and replace blower cord assembly.
		CB1 trips to OFF with no delay.	Proceed to Ident. B4.
B4	Disconnect ac harness connector P3 from connector on lower back portion of +5 V power supply assembly. Set circuit breaker CB1 to ON position.	CB1 remains ON.	Remove and replace +5 V power supply assembly, H7104D.
		CB1 trips to OFF.	Proceed to Ident. B5.
B5	Disconnect ac harness connector P2 from connector on lower back portion of +2.5 V power supply assembly. Set circuit breaker CB1 to ON position.	CB1 remains ON.	Remove and replace +2.5 V power supply assembly, H7104.
		CB1 trips to OFF.	Proceed to Ident. B6.

Table 5-1 Fault Isolation Procedure (Cont)

Ident.	Procedure	Indication	Action
B6	Disconnect ac harness connector P1 from connector on lower rear portion of power controller. Set circuit breaker CB1 to ON position.	CB1 remains ON. CB1 trips to OFF.	Remove and replace ac harness. If battery backup unit is installed as an option, proceed to Ident. B7. If battery backup unit is not installed, remove and replace power controller.
B7	Disconnect battery backup power cord from ac outlet on power controller. Set circuit breaker CB1 to ON position.	CB1 remains ON. CB1 trips to OFF.	Remove and replace battery back-up unit. Remove and replace power controller.
C1	Set REMOTE/OFF/LOCAL switch on power controller at LOCAL position. Disconnect console power cable assembly connector P2 from J2 on control panel. Measure voltage between pins 7 and 8 of console power cable assembly connector P2.	+12 Vdc is present. +12 Vdc is not present.	Remove and replace control panel. Proceed to Ident. C2
C2	Disconnect console power cable assembly connector P3 from J3 of power controller. Measure voltage between pins 1 and 2 of connector J3 on power controller.	+12 Vdc is present. +12 Vdc is not present.	Remove and replace console power cable assembly. Proceed to Ident. C3.
C3	Disconnect status cable assembly from ac power controller. Measure voltage between pins 5 and 9 of status cable connector.	+12 Vdc is present. +12 Vdc is not present.	Remove and replace power controller. Remove and replace +2.5 V power supply assembly, H7104C.
D1	If connected, disconnect cables from DEC POWER BUS/NORMAL AND DELAYED connectors on power controller. If not connected proceed to Ident. D2.	CPU STATE/POWER and POWER OK indicators illuminate. CPU STATE/POWER and POWER OK remain off.	Overtemperature condition in remote unit. Proceed to Ident. D2.

Table 5-1 Fault Isolation Procedure (Cont)

Ident.	Procedure	Indication	Action
D2	Monitor pin 2 of DEC POWER BUS/NORMAL or DELAYED connector.	Ground is detected.	Remove and replace power controller.
		Open is detected.	Proceed to Ident. D3.
D3	Set REMOTE/OFF/LOCAL switch on power controller at LOCAL.	CPU STATE/POWER and POWER OK indicators illuminate.	Remove and replace control panel. If fault persists, remove and replace console power cable assembly. If fault still persists, remove and replace power controller.
		CPU STATE/POWER and POWER OK indicators do not illuminate.	Proceed to Ident. D4.
D4	Disconnect status cable assembly from J1 of status board within power controller. Measure voltage between pins 16 and 9 of cable assembly connector.	Voltage between pins 16 and 9 is +5 V.	Remove and replace +2.5 V power supply assembly, H7104C. NOTE: Check inrush resistor R1 on bottom panel assembly of the 2.5 V power supply assembly. If this resistor has blown, also remove and replace +5 V power supply assembly, H7104D.
		Voltage between pins 16 and 9 is not +5 V.	Remove and replace 5 V power supply assembly, H7014D.
E1	Physically, by careful touch, test the temperature of the output panel assemblies of the +2.5 V and +5 V power supply assemblies (i.e., carefully touch the top of the power supply assemblies in the region between the output bus connectors and the right-hand side of the assemblies).	+2.5 V power supply assembly output panel is hotter than the output panel assembly of the +5 V power supply assembly.	Remove and replace +2.5 V power supply assembly, H7014C.
		+5 V power supply assembly output panel is hotter than the +2.5 V power supply assembly output panel.	Proceed to Ident. E2.

Table 5-1 Fault Isolation Procedure (Cont)

Ident.	Procedure	Indication	Action
E2	Perform turnoff procedure, Paragraph 2.2.2. Disconnect control cable assembly from J1 of 2.5 V control board within +2.5 V power supply assembly. Monitor pin 12 of control cable assembly.	Ground level signal at pin 12.	Remove and replace +5 V power supply assembly, H7014D.
		Open at pin 12.	Remove and replace +2.5 V power supply assembly, H7014C.
F1	Set circuit breaker CB1 on power controller at OFF. Disconnect the +5 V and 5 V return power cable assemblies from the 5 V and 5 V RTN bus bars on the +5 V power supply assembly. Set circuit breaker CB1 on power controller at ON.	+5 V FAIL and REG FAIL indicators illuminate.	Fault exists in the +5 V load. To isolate the fault area, proceed to Ident. F2.
		+5 V FAIL, OVER-CURRENT, and REG FAIL indicators illuminate.	Remove and replace +5 V power supply assembly, H7104D.
F2	Set circuit breaker CB1 on power controller at OFF. Connect the +5 V and 5 V Return power cable assemblies to the 5 V and 5 V RTN bus bars on the 5 V power supply. Set circuit breaker CB1 on power controller at ON. Disconnect P1 of TU58 cable assembly from J1 of TU58 controller board.	CPU STATUS/ POWER and POWER OK indicators illuminate.	Fault exists in TU58 controller board.
		CPU STATUS/ POWER and POWER OK indicators do not illuminate.	Proceed to Ident. F3.
F3	Disconnect J1 of power option harness from P4 of UNIBUS option backplane.	CPU STATUS/ POWER and POWER OK indicators illuminate.	Fault exists in UNIBUS option backplane.
		CPU STATUS/ POWER and POWER OK indicators do not illuminate.	Proceed to Ident. F4.

Table 5-1 Fault Isolation Procedure (Cont)

Ident.	Procedure	Indication	Action
F4	Disconnect J2 of power option harness from P4 of UNIBUS option backplane.	CPU STATUS/ POWER and POWER OK indicators illumi- nate.	Fault exists in UNIBUS option backplane.
		CPU STATUS/ POWER and POWER OK indicators do not il- luminate.	Proceed to Ident. F5.
F5	Set circuit breaker CB1 on power controller at OFF. Disconnect terminal rings E2 and E3 of the power option harness from CPU backplane lugs labeled N2 and N1, respectively, in engineering drawing 7016707. Disconnect terminal rings E4 and E5 of the power option harness from CPU backplane lugs labeled M1 and M2, respectively, in engineering drawing 7016707. Set circuit breaker CB1 on power controller at ON.	CPU STATUS/ POWER and POWER OK indicators illumi- nate.	Fault exists in power op- tion harness.
		CPU STATUS/ POWER and POWER OK indicators do not il- luminate.	Fault exists in CPU back- plane.
G	Set circuit breaker CB1 on power controller at OFF. Disconnect the +2.5 V and 2.5 V return power cable assemblies from the 2.5 V and 2.5 V RTN bus bars on the +2.5 V power supply assembly. Set circuit breaker CB1 on power controller at ON.	+2.5 V FAIL and REG FAIL indicators illumi- nate and OVER- VOLTAGE indicator blinks.	Fault exists in CPU back- plane.
		+2.5 V FAIL, OVER- CURRENT, and REG FAIL indicators illumi- nate.	Remove and replace +2.5 V power supply assembly, H7104C.
H1	Disconnect P4 of power signal harness from J3 of +5 V power supply assembly.	CPU STATE/POWER and POWER OK in- dicators illuminate.	Fault exists in +15 V load. Proceed to Ident. J1 to isolate the fault area.
		REG FAIL indicator is illuminated.	Proceed to Ident. H2.

Table 5-1 Fault Isolation Procedure (Cont)

Ident.	Procedure	Indication	Action
H2	Disconnect P1 of power signal harness from J1 of +2.5 V power supply assembly.	CPU STATE/POWER and POWER OK indicators illuminate.	Fault exists in +15 VB or +12 VB load. Proceed to Ident. K1 to isolate the fault area.
		REG FAIL indicator is illuminated.	Proceed to Ident. H3.
H3	Measure voltages between pins 1 and 2 and pins 2 and 3 at J3 on the +5 V power supply assembly.	Voltages between pins are as follows: 1 and 2, +15 V 2 and 3, -15 V	Proceed to Ident. H4.
		Voltages between pins are not as follows: 1 and 2, +15 V 2 and 3, -15 V	Fault exists in ± 15 V regulator. Remove and replace +5 V power supply assembly, H7104D.
H4	Measure voltage between pins 5 and 9, pins 1 and 3, and pins 12 and 15 at J3 on the +5 V power supply assembly.	+5 VB is not present between pins 5 and 9, +12 VB is present between pins 1 and 3, and -5 VB is present between pins 12 and 15.	Fault exists in ± 5 VB regulator. Remove and replace +2.5 V power supply assembly, H7104C.
		+5 VB is not present between pins 5 and 9, +12 VB is not present between pins 1 and 3, and -5 VB is present between pins 12 and 15.	Fault exists in the +12 VB regulator. Remove and replace +2.5 V power supply assembly, H7104C.
		+5 VB is not present between pins 5 and 9, +12 VB is not present between pins 1 and 3, and -5 VB is not present between pins 12 and 15.	Fault exists in the ± 5 VB regulator. Remove and replace +2.5 V power supply assembly, H7104C.
J1	Connect P4 of power signal harness to J3 of +5 V power supply. Disconnect P1 of power option harness from CPU backplane connector J2.	CPU STATE/POWER and POWER OK indicators illuminate.	Fault exists in ± 15 V load in UNIBUS option backplane or power option harness.
		REG FAIL indicator is illuminated.	Proceed to Ident. J2.

Table 5-1 Fault Isolation Procedure (Cont)

Ident.	Procedure	Indication	Action
J2	Disconnect P2 of power signal harness from CPU backplane connector J3.	CPU STATE/POWER and POWER OK indicators illuminate.	Fault exists in ± 15 V load in CPU backplane.
		REG FAIL indicator is illuminated.	Proceed to Ident. J3.
J3	Disconnect P3 of power signal harness from CPU backplane connector J1.	CPU STATE/POWER and POWER OK indicators illuminate.	Fault exists in ± 15 V load in CPU backplane.
		REG FAIL indicator is illuminated.	Remove and replace power signal harness.
K1	Connect P1 of power signal harness to J1 of +2.5 V power supply assembly. Disconnect P1 of TU58 cable assembly from J1 of TU58 controller board.	CPU STATE/POWER and POWER OK indicators illuminate.	Fault exists in TU58 controller board.
		REG FAIL indicator is illuminated.	Proceed to Ident. K2.
K2	Disconnect P3 of TU58 cable assembly from slot 6, section B of CPU backplane.	CPU STATE/POWER and POWER OK indicators illuminate.	Remove and replace TU58 cable assembly.
		REG FAIL indicator is illuminated.	Proceed to Ident. K3.
K3	Disconnect P2 of power signal harness from CPU backplane connector J3.	CPU STATE/POWER and POWER OK indicators illuminate.	Fault exists in the ± 5 VB or +12 VB load in CPU backplane.
		REG FAIL indicator is illuminated.	Proceed to Ident. K4.
K4	Disconnect P3 of power signal harness from CPU backplane connector J1.	CPU STATE/POWER and POWER OK indicators illuminate.	Fault exists in +5 VB or +12 VB load in CPU backplane.
		REG FAIL indicator is illuminated.	Remove and replace power signal harness.

5.2 BATTERY BACKUP OPERATIONAL VERIFICATION

The H7112 battery backup unit can be functionally verified by running the ECKAX diagnostics under manual intervention (SEC:MANUAL). This diagnostic requires power interruption through manual intervention (i.e., manually using CBI on power controller to interrupt power). The battery backup unit should keep memory valid and return the diagnostic to a normal completion cycle. To verify proper operation of the battery backup unit, perform the following procedure.

1. Perform H7104 power system turn-on procedure. (Refer to paragraph 2.2.1.)
2. Set five-position keyswitch on control panel at LOCAL.
3. Insert tape containing program ECSAA into TU58 tape slot.
4. On console, type

B DDA0

Then press RETURN. The console prints

%%

Then, after approximately 2-1/2 minutes, the console prints the following:

DIAGNOSTIC SUPERVISOR. ZZ-ECSAA-5.3-113
1-JAN-1980 00:00:00.00 DS>

5. Remove ECSAA program tape from TU58 tape slot.
6. Insert tape containing program ECKAX into TU58 tape slot.
7. On console, type

ATT KA750 CMI KA0 NO NO YES 0 0

Then press RETURN.

8. On console, type

SEL KA0

Then press RETURN.

9. On console, type

RU ECKAX/SE:MAN/TE:3

Then press RETURN. After approximately 1 minute, the console prints the following:

PROGRAM: VAX-11/750 Specific CPU Cluster Exerciser – ZZ-ECKAX-1, REV 1.0,
9 TEST TESTING: _KA0

Is this system equipped with a battery backup?

(If no, then set the front panel switch to the HALT position.)

[(NO), YES]

10. On console, type

YES

Then press RETURN. Console prints the following:

Before continuing, set the front panel switch to HALT/RESTART

Good Restart Parameter Block Subtest – This subtest will restart itself if the RPB is properly interpreted. Throw the breaker switch to power fail . . .

11. Set five-position keyswitch on control panel at HALT/RESTART.

12. On power controller, set circuit breaker CBI at OFF. Then set circuit breaker CBI at ON. Console prints the following:

%%

Bad Checksum Subtest – This subtest will halt the processor with a halt code of 11. After this has happened the subtest is restarted by typing S 100 <CR> on the console terminal. Throw the breaker switch to power fail . . .

13. On power controller, set circuit breaker CBI at OFF. Then set circuit breaker CBI at ON. Console prints the following:

%%

00000000 11

>>>

14. On console, type

S 100

Then press RETURN. Console prints the following:

Search for Good RPB – This subtest will restart itself if the good RPB is found and interpreted properly. Throw the breaker switch to power fail . . .

15. On power controller, set circuit breaker CB1 at OFF. Then set circuit breaker CB1 at ON. Console prints the following:

%%

Warm Start Flag Subtest – This subtest will halt the processor with a halt code of 12. After this has happened the subtest is restarted by typing S 100 <CR> on the console terminal. Throw the breaker switch to power fail . . . Before power fail set front panel switch to the HALT position.

16. On power controller, set circuit breaker CB1 at OFF. Then set circuit breaker CB1 at ON. Console prints the following:

%%

00000000 12
>>>

17. Set five-position keyswitch on control panel at HALT position.

18. On console, type

S 100

Then press RETURN. Console prints the following:

NOTE

The front panel switch must be in the HALT for this test to operate properly.

HALT expected with following printout:

00006136 06

To continue from console mode do the following:

D/G F 100 <CR> and then C <CR>

00006136 06

>>>

19. On console, type

D/G F 100

Then press RETURN.

20. On console, type

C

Then press RETURN. Console prints the following:

HALT expected with following printout:

0000633F 04

To continue from console mode do the following:

D/G F 100 <CR> and then C <CR>

0000633F 04

>>>

21. On console, type
D/G F 100
Then press RETURN.
22. On console, type
C
Then press RETURN. Console prints the following:
HALT expected with following printout:
0000650C 04
To continue from console mode do the following:
D/G F 100 <CR> and then C <CR>
0000650C 04
>>>
23. On console, type
D/G F 100
Then press RETURN.
24. On console, type
C
Then press RETURN. Console prints the following:
HALT expected with following printout:
00006688 0A
To continue from console mode do the following:
D/G F 100 <CR> and then C <CR>
00006688 0A
>>>
25. On console, type
D/G F 100
Then press RETURN.
26. On console, type
C
Then press RETURN. Console prints the following:
HALT expected with following printout:
00006808 0A
To continue from console mode do the following:
D/G F 100 <CR> and then C <CR>
00006808 0A
>>>

27. On console, type
D/G F 100
Then press RETURN.
28. On console, type
C
Then press RETURN. Console prints the following:
HALT expected with following printout:
00006988 0A
To continue from console mode do the following:
D/G F 100 <CR> and then C <CR>
00006988 0A
>>>
29. On console, type
D/G F 100
Then press RETURN.
30. On console, type
C
Then press RETURN. Console prints the following:
HALT expected with following printout:
00006B08 0A
To continue from console mode do the following:
D/G F 100 <CR> and then C <CR>
00006B08 0A
>>>
31. On console, type
D/G F 100
Then press RETURN.
32. On console, type
C
Then press RETURN. Console prints the following:
..END OF RUN. 0 ERRORS DETECTED. PASS COUNT: 1. TIME: (CURRENT)
DS>
33. The test is now complete. Remove ECKAX program tape from TU58 tape slot.

5.3 REMOVAL AND REPLACEMENT INSTRUCTIONS

5.3.1 +5 V Power Supply Assembly Removal Procedure

1. Set circuit breaker CB1 on power controller at OFF.

WARNING

To prevent personal injury make certain that circuit breaker CB1 on power controller is set at OFF.

2. Remove screws securing power cable assemblies to +5 V and 5 V RTN bus bars on top of +5 V power supply assembly. (Screws will be used on replacement assembly.)
3. Disconnect P4 of power signal harness from J3 on top of +5 V power supply assembly.
4. Remove the screw (top) which secures the ground wire to the +5 V power supply assembly.
5. Loosen the four screws securing the front panel assembly to the power controller, +2.5 V power supply assembly, +5 V power supply assembly, and to the frame to the right of the +5 V power supply assembly.
6. Gently pull the top portion of the front panel assembly away from the H7104 power system. Then, while moving the top of the front panel assembly toward you, gently exert an upward pressure. The tabs on the front panel assembly will disengage from the connecting slots on the +2.5 V power supply assembly and +5 V power supply assembly.
7. Remove the screw which was used to secure the front panel assembly to the +5 V power supply assembly. (Screw will be used on replacement assembly.)
8. Disconnect control cable assembly from J1 of the 5 V control board within the +5 V power supply assembly.
9. Remove the screw (lower center of the +5 V power supply assembly) which secures the +5 V power supply assembly to the VAX-11/750 cabinet assembly.
10. Slide the +5 V power supply assembly approximately halfway out of the VAX-11/750 cabinet assembly.
11. Disconnect P3 of the ac harness from the 15-pin connector on the lower back portion (portion toward the front of the VAX-11/750 cabinet) of the +5 V power supply assembly.

CAUTION

To avoid damage to the +5 V power supply assembly, maintain a firm grip on the handle while removing the +5 V power supply assembly from the cabinet assembly.

12. Grasp the handle of the +5 V power supply assembly and gently slide the assembly out of the VAX-11/750 cabinet assembly.

5.3.2 +5 V Power Supply Assembly Installation Procedure

CAUTION

To avoid damage to the +5 V power supply assembly, maintain a firm grip on the handle while sliding the +5 V power supply assembly into the cabinet assembly.

1. Grasp the handle of the +5 V power supply assembly and gently slide the assembly halfway into the VAX-11/750 cabinet assembly.
2. Connect P3 of the ac harness to the 15-pin connector on the lower rear portion of the +5 V power supply assembly.
3. Slide the +5 V power supply assembly into proper position within the VAX-11/750 cabinet assembly.
4. Secure the +5 V power supply assembly to the VAX-11/750 cabinet assembly with the screw which was removed in step 9 of the removal procedure.

CAUTION

While performing step 5, make certain of proper positioning of red stripe on the ribbon cable. Improper connection may cause equipment damage.

5. Connect control cable assembly to J1 of 5 V control board. Make certain that the red stripe on the ribbon cable is on the right-hand side of the connector when the connector is connected to the 5 V control board. (Refer to cabling diagrams of engineering drawing 7016707.)
6. Insert the tabs of the front panel assembly into the appropriate slots on the +2.5 V power supply assembly and the +5 V power supply assembly. Then, move the top of the front panel assembly inward until it engages the mounting screws on the power controller, the +2.5 V power supply assembly, and the frame to the right of the +5 V power supply assembly.
7. Insert screw removed in step 7 of the removal procedure into the appropriate hole on the top of the +5 V power supply assembly.
8. Tighten the screws, which secure the front panel assembly to the power controller, +2.5 V power supply assembly, +5 V power supply assembly, and frame to the right of the +5 V power supply assembly.
9. Connect P4 of the power signal harness to J3 on top of the +5 V power supply assembly.
10. Secure the +5 V and +5 V RTN power cable assemblies to the +5 V and +5 V RTN bus bars on the top of the +5 V power supply assembly using the screws removed in step 2 of the removal procedure. Secure screws using 22 inch-pounds of force.
11. Secure the ground wire to the top of the +5 V power supply assembly using the screw removed in step 4 of the removal procedure.

12. Make certain that the LO/NORMAL/HI switches on the top of the +5 V power supply assembly, and +2.5 V power supply assembly are set at NORMAL position.
13. Set circuit breaker CB1 on power controller at ON.

5.3.3 +2.5 V Power Supply Assembly Removal Procedure

1. Set circuit breaker CB1 on power controller at OFF.

WARNING

To prevent personal injury make certain that the circuit breaker CB1 on power controller is set at OFF.

2. Remove screws securing power cable assemblies to +2.5 V and 2.5 V RTN bus bars on top of +2.5 V power supply assembly. (Screws will be used on replacement assembly.)
3. Disconnect P1 and P5 of power signal harness from J1 and J2, respectively, on top of +2.5 V power supply assembly.
4. Disconnect P1 of the remote sense cable assembly from J4 on top of +2.5 V power supply assembly.
5. Remove the screw securing ground wire to the top of the +2.5 V power supply assembly. (Screw will be used on replacement assembly.)
6. Loosen the four screws securing the front panel assembly to the power controller, +2.5 V power supply assembly, +5 V power supply assembly, and to the frame to the right of the +5 V power supply assembly.
7. Gently pull the top portion of the front panel assembly away from the H7104 power system. Then, while moving the top of the front panel assembly toward you, gently exert an upward pressure. The tabs on the front panel assembly will disengage from the connecting slots on the +2.5 V power supply assembly and +5 V power supply assembly.
8. Remove the screw which was used to secure the front panel assembly to the +2.5 V power supply assembly. (Screw will be used on replacement assembly.)
9. Disconnect control cable assembly from J1 of the 2.5 V control board within the +2.5 V power supply assembly.
10. Disconnect status cable assembly from J1 on the status card at the front of the power controller.
11. Remove the screw (lower center of the +2.5 V power supply assembly) which secures the +2.5 V power supply assembly to the VAX-11/750 cabinet assembly.
12. Slide the +2.5 V power supply assembly approximately halfway out of the VAX-11/750 cabinet assembly.
13. Disconnect P2 of the ac harness from the 15-pin connector on the lower back portion (portion toward the front of the VAX-11/750 cabinet) of the +2.5 V power supply assembly.

14. Disconnect P1 of the battery backup harness from the 4-pin connector on the lower back portion of the +2.5 V power supply assembly.

CAUTION

To avoid damage to the +2.5 V power supply assembly, maintain a firm grip on the handle while removing the +2.5 V power supply assembly from the cabinet assembly.

15. Grasp the handle of the +2.5 V power supply assembly and gently slide the assembly out of the VAX-11/750 cabinet assembly.

5.3.4 +2.5 V Power Supply Assembly Installation Procedure

CAUTION

To avoid damage to the +2.5 V power supply assembly, maintain a firm grip on the handle while sliding the +2.5 V power supply assembly into the cabinet assembly.

1. Grasp the handle of the +2.5 V power supply assembly and gently slide the assembly halfway into the VAX-11/750 cabinet assembly.
2. Connect P2 of the ac harness to the 15-pin connector on the lower rear portion of the +2.5 V power supply assembly (portion toward the front of the VAX-11/750 cabinet).
3. Connect P1 of the battery backup harness to the 4-pin connector on the lower rear portion of the +2.5 V power supply assembly.
4. Slide the +2.5 V power supply assembly into proper position within the VAX-11/750 cabinet assembly.
5. Secure the +2.5 V power supply assembly to the VAX-11/750 cabinet assembly with the screw which was removed in step 11 of the removal procedure.

CAUTION

While performing steps 6 and 7, make certain of proper positioning of red stripe on the ribbon cable. Improper connection may cause equipment damage.

6. Connect control cable assembly to J1 of 2.5 V control board. Make certain that the red stripe on the ribbon cable is on the right-hand side of the connector when the connector is connected to the 2.5 V control board. (Refer to cabling diagrams in engineering drawing 7016707.)
7. Connect status cable assembly to J1 of the status card at the top front of the power controller. Make certain that the red stripe on the ribbon cable is on the left-hand side of the connector when connected to the status card. (Refer to cabling diagrams in engineering drawing 7016707.)
8. Insert the tabs of the front panel assembly into the appropriate slots on the +2.5 V power supply assembly and the +5 V power supply assembly. Then, move the top of the front panel assembly inward until it engages the mounting screws on the power controller, the +5 V power supply assembly, and the frame to the right of the +5 V power supply assembly.

9. Insert screw removed in step 8 of the removal procedure into the appropriate hole on the top of the +2.5 V power supply assembly.
10. Tighten the screws which secure the front panel assembly to the power controller, +2.5 V power supply assembly, +5 V power supply assembly, and frame to the right of the +5 V power supply assembly.
11. Connect P1 and P5 of the power signal harness to J1 and J2, respectively, on top of the +2.5 V power supply assembly.
12. Secure the +2.5 V and 2.5 V RTN power cable assemblies to the +2.5 V and 2.5 V RTN bus bars on the top of the +2.5 V power supply assembly using the screws removed in step 4 of the removal procedure. Secure screws using 22 inch-pounds of force.
13. Connect P1 of the remote sense cable assembly to J4 on top of +2.5 V power supply assembly.
14. Secure the ground wire to the top of the +2.5 V power supply assembly using the screw removed in step 5 of the removal procedure.
15. Make certain that the LO/NORMAL/HI switch on the top of the +2.5 V power supply assembly and +5 V power supply assembly are set at NORMAL position.
16. Set circuit breaker CB1 on power controller at ON.

5.3.5 Power Controller Removal Procedure

1. Set circuit breaker CB1 on power controller at OFF.
2. Disconnect power cord from ac facility power outlet.

WARNING

To prevent personal injury make certain that the power cord from the controller is disconnected from the ac facility power outlet.

3. Disconnect P3 of console power cable assembly from J3 on top of power controller.
4. Disconnect P3 of battery backup harness from J2 on top of power controller.
5. Disconnect P1 of airflow patch cable assembly from J1 on top of power controller.
6. Remove the screw which secures the ground wire to the top of the power controller. (Screw is to be used on replacement assembly.)
7. Disconnect status cable assembly from J1 of status card at top front of power controller.
8. Disconnect cables, if attached, to the DEC POWER BUS/NORMAL and DELAYED connectors. (Make note of position of cables, if attached.)
9. Loosen the four screws securing the front panel assembly to the power controller, +2.5 V power supply assembly, +5 V power supply assembly, and to the frame to the right of the +5 V power supply assembly.

10. Gently pull the top portion of the front panel assembly away from the H7104 power system. Then, while moving the top of the front panel assembly toward you, gently exert an upward pressure. The tabs on the front panel assembly will disengage from the connecting slots on the +2.5 V power supply assembly and +5 V power supply assembly.
11. Remove the screw which was used to secure the front panel assembly to the power controller. (Screw will be used on replacement assembly.)
12. Remove the four screws securing the power controller to the cabinet assembly, i.e., The three screws in the vertical frame on the left side of the power controller and the single screw on the top right rear portion of the power controller.
13. Slide the power controller halfway out of the VAX-11/750 cabinet assembly.
14. Disconnect P1 of the ac harness from the 15-pin connector on the lower back portion (portion toward the front of the VAX-11/750 cabinet) of the power controller.
15. Disconnect P2 of the battery backup harness from the 9-pin connector on the lower back portion of the power controller.
16. Disconnect blower cable plug from ac outlet on the back portion of the power controller.
17. If a battery backup unit is installed as an option, disconnect the battery backup unit power cord plug from the ac outlet on the back portion of the power controller.

CAUTION

To avoid damage to the power controller maintain a firm grip on the handle while removing the power controller from the VAX-11/750 cabinet assembly.

18. Grasp the handle of the power controller and gently slide the assembly out of the VAX-11/750 cabinet assembly.

5.3.6 Power Controller Installation Procedure

CAUTION

To avoid damage to the power controller, maintain a firm grip on the handle while installing the power controller in the VAX-11/750 cabinet assembly.

1. Grasp the handle of the power controller and gently slide the power controller halfway into the VAX-11/750 cabinet assembly.
2. Connect P1 of the ac harness to the 15-pin connector on the lower back portion (portion toward the front of the VAX-11/750 cabinet) of the power controller.
3. Connect P2 of the battery backup harness to the 9-pin connector on the lower back portion of the power controller.
4. Connect blower cable plug to an ac outlet on the back portion of the power controller.

5. If a battery backup unit is installed as an option, connect the battery backup unit power cord plug to an ac outlet on the back portion of the power controller.
6. Slide the power controller into position in the VAX-11/750 cabinet assembly.
7. Secure the power controller to the cabinet assembly using the four screws removed in step 12 of the removal procedure.
8. Connect P3 of console power cable assembly to J3 on top of power controller.
9. Connect P3 of battery backup harness to J2 on top of power controller.
10. Connect P1 of airflow patch cable assembly to J1 on top of power controller.
11. Secure the ground wire to the top of the power controller using the screw removed in step 6 of the removal procedure.

CAUTION

While performing step 12, make certain of proper positioning of red stripe on ribbon cable. Improper connection may cause equipment damage.

12. Connect status cable assembly connector to J1 of the status card at the top front of the power controller. Make certain that the red stripe on the ribbon cable is on the left-hand side of the connector when connected to the status card. (Refer to cabling diagrams in engineering drawing 7016707.)
13. Insert the tabs of the front panel assembly into the appropriate slots on the +2.5 V power supply assembly and the +5 V power supply assembly. Then, move the top of the front panel assembly inward until it engages the mounting screws on the +2.5 V power supply assembly, the +5 V power supply assembly, and the frame to the right of the +5 V power supply assembly.
14. Insert screw removed in step 11 of the removal procedure into the appropriate hole on the top of the power controller.
15. Tighten the four screws securing the front panel assembly to the power controller, +2.5 V power supply assembly, +5 V power supply assembly, and the frame to the right of the +5 V power supply assembly.
16. Reconnect cables if removed in step 8 of the removal procedure to the appropriate DEC POWER BUS connectors.
17. Set circuit breaker CBI on power controller at OFF.
18. Set power controller LOCAL/OFF/REMOTE switch at REMOTE.
19. Make certain that the HI/NORMAL/LO switches on the +5 V power supply assembly and +2.5 V power supply assembly are set at NORMAL.
20. Connect power controller power cord to ac facility power outlet.
21. Set circuit breaker CBI on power controller at ON.

Reader's Comments

VAX-11/750 H7104 Power System
Technical Description
EK-PS750-TD-002

Your comments and suggestions will help us in our continuous effort to improve the quality and usefulness of our publications.

What is your general reaction to this manual? In your judgement is it complete, accurate, well organized, well written, etc? Is it easy to use? _____

What features are most useful? _____

What faults or errors have you found in the manual? _____

Does this manual satisfy the need you think it was intended to satisfy? _____

Does it satisfy *your* needs? _____ Why? _____

Please send me the current copy of the *Technical Documentation Catalog*, which contains information on the remainder of DIGITAL's technical documentation.

Name _____	Street _____
Title _____	City _____
Company _____	State/Country _____
Department _____	Zip _____

Additional copies of this document are available from:

Digital Equipment Corporation
Accessories and Supplies Group
Cotton Road
Nashua, NH 03060

Attention *Documentation Products*
Telephone 1-800-258-1710

Order No. EK-PS750-TD

Fold Here

Do Not Tear -- Fold Here and Staple

digital



No Postage
Necessary
if Mailed in the
United States

BUSINESS REPLY MAIL

FIRST CLASS PERMIT NO. 33 MAYNARD, MA.

POSTAGE WILL BE PAID BY ADDRESSEE

**Digital Equipment Corporation
Educational Services Development and Publishing
1925 Andover Street, B01
Tewksbury, MA 01825**

